

P-JAL-B-253

G101229

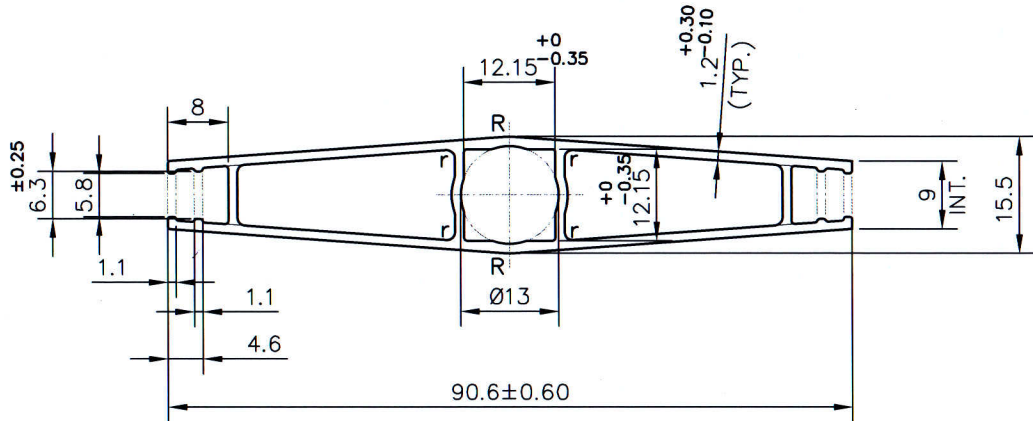

NOTE:-

r= 1.00 RADIUS (4 PLACES)
R= 7.75 RADIUS (2 PLACES)

1. STRAIGHTNESS= 1.5mm/M
2. TWIST= 1.7mm/M
3. ANGULARITY= ±2°
4. FLATNESS= 0.007xWIDTH

(Q00400)



SYMBOL OF QUALITY
AN ISO 9001 COMPANY

JINDAL ALUMINIUM LTD.
 BHIWADI-301019 (INDIA)

1. ALL DIMENSIONS ARE IN mm.
2. ROUND OFF ALL SHARP CORNERS WITH 0.40 mm.
3. TOLERANCES WILL BE AS PER BS:EN-755-9 , UNLESS OTHERWISE SPECIFIED

	NAME	DATE
DRAWN	ASHUTOSH	03-07-2023
CHECKED	<i>[Signature]</i>	10/8/23
APPROVED	<i>[Signature]</i>	10/08/23
SCALE		1:1
AREA mm ²		291.58
PERIMETER mm.		236.62
WEIGHT kg/m		0.787
DRAWING No.		SECTION No.
P-JAL-B-253		
G101229		G101229

PARTY'S NAME	M/s. SYSTEMAIR INDIA DRAWINGS	
PARTY'S DRAWING No.	AS PER DRAWING -BLADE FRAME	
ALLOY & TEMPER	6063-T6	PRODUCT CODE:-082 HSN CODE:-76042100
DESCRIPTION	AIR GRILL SECTION	