

P-JAL-B-287-1

G101257

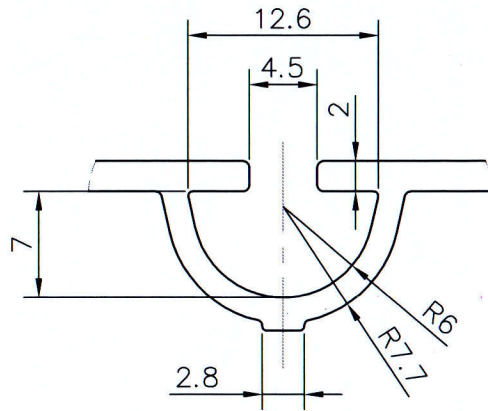

DETAIL-A
SCALE 2:1

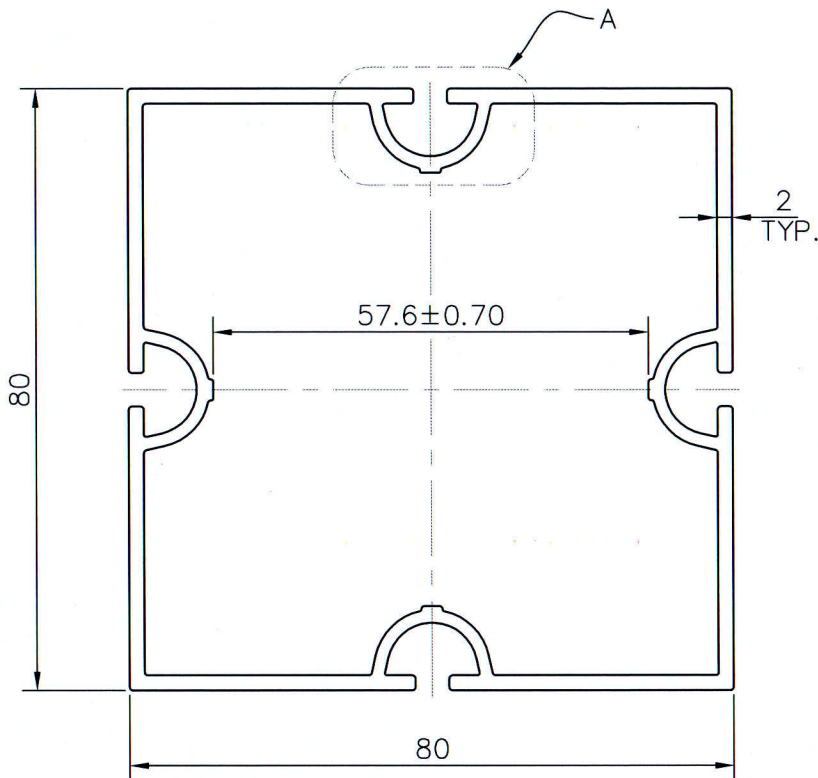

1. STRAIGHTNESS= 1.7mm/M
2. TWIST= 1.7mm/M
3. ANGULARITY= ±2°
4. FLATNESS= 0.007xWIDTH

(Q00750)

 SYMBOL OF QUALITY AN ISO 9001 COMPANY	JINDAL ALUMINIUM LTD. BHIWADI-301019 (INDIA)	NAME	DATE
		DRAWN	ASHUTOSH
1. ALL DIMENSIONS ARE IN mm. 2. ROUND OFF ALL SHARP CORNERS WITH 0.40 mm. 3. TOLERANCES WILL BE AS PER BS:EN-755-9 , UNLESS OTHERWISE SPECIFIED		CHECKED	16/8/23
		APPROVED	16/08/23
PARTY'S NAME MEROFORM INDIA (P) LTD.		SCALE	1:1
		AREA mm ²	754.50
PARTY'S DRAWING No. AS PER DRAWING		PERIMETER mm.	429.64
		WEIGHT kg/m	2.037
ALLOY & TEMPER 6063 T6		DRAWING No.	SECTION No.
		P-JAL-B-287-1	7000001395
DESCRIPTION DISPLAY SECTION		G101257	G101257
		PRODUCT CODE: -047	
		HSN CODE: -76042100	