

P-JAL-B-250-1

G101331

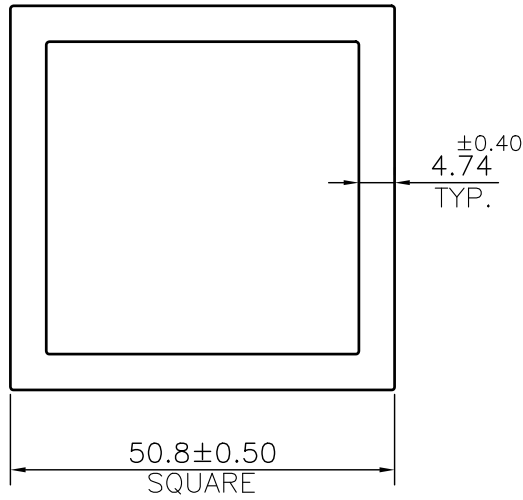

1. STRAIGHTNESS= 1.7mm/M
2. TWIST= 1.7mm/M
3. ANGULARITY= $\pm 2^\circ$
4. FLATNESS= 0.007xWIDTH

Q00646

CONTROLLED COPY



SYMBOL OF QUALITY
AN ISO 9001 COMPANY

JINDAL ALUMINIUM LTD.
BANGALORE-560073 (INDIA)

	NAME	DATE
DRAWN	ASHUTOSH	29-08-2023
CHECKED	PARVESH	06-09-2023
APPROVED	J.N RAI	06-09-2023

1. ALL DIMENSIONS ARE IN mm.
2. ROUND OFF ALL SHARP CORNERS WITH 0.40 mm.
3. TOLERANCES WILL BE AS PER BS:EN-755-8 , UNLESS OTHERWISE SPECIFIED

SCALE	1:1
AREA mm ²	873.298
PERIMETER mm.	202.513
WEIGHT kg/m	2.358

PARTY'S NAME	JANGID ENGINEERING WORKS		DRAWING No.	SECTION No.
PARTY'S DRAWING No.	AS PER DRAWING		P-JAL-B-250-1	7000001482
ALLOY & TEMPER	6063 T6	PRODUCT CODE:-009	G101331	G101331
		HSN CODE:- 76082000		
DESCRIPTION	SQUARE TUBE SECTION			