

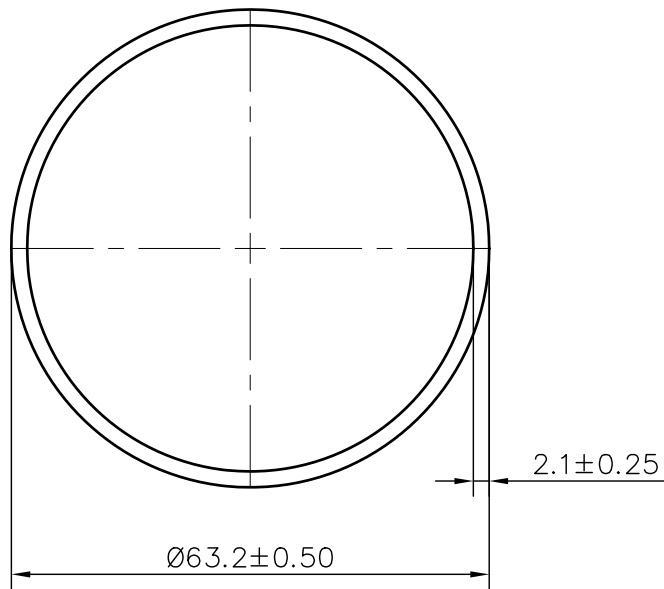

P-JAL-B-243-1

G101575



- 1. STRAIGHTNESS= 1.7mm/M
- 2. TWIST= 1.7mm/M
- 3. ANGULARITY= ±2°
- 4. FLATNESS= 0.007xWIDTH

(Q00566)

 SYMBOL OF QUALITY AN ISO 9001 COMPANY	JINDAL ALUMINIUM LTD. BHIWADI-301019 (INDIA)		NAME	DATE	
			DRAWN	ASHUTOSH	04-10-2023
1. ALL DIMENSIONS ARE IN mm. 2. ROUND OFF ALL SHARP CORNERS WITH 0.40 mm. 3. TOLERANCES WILL BE AS PER BS:EN-755-8 , UNLESS OTHERWISE SPECIFIED			CHECKED	PARVESH	04-11-2023
			APPROVED	J.N.RAI	04-11-2023
PARTY'S NAME SHIFTAIR INDIA PVT. LTD.			SCALE		1:1
			AREA mm ²		403.10
PARTY'S DRAWING No. AS PER DRAWING			PERIMETER mm.		198.55
			WEIGHT kg/m		1.088
ALLOY & TEMPER 6063 T6			DRAWING No.		SECTION No.
			P-JAL-B-243-1		7000001739
DESCRIPTION ROUND TUBE			G101575		G101575
			PRODUCT CODE: -006		
			HSN CODE: - 76082000		