

P-JAL-B-375

G101733

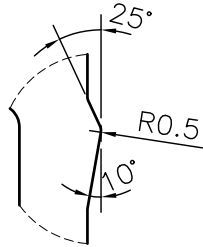

DETAIL B
SCALE 3:1

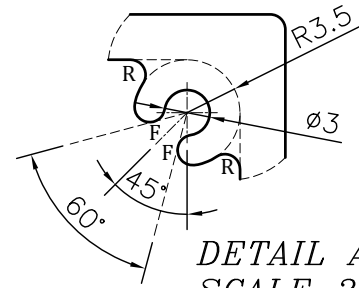

DETAIL A
SCALE 2:1

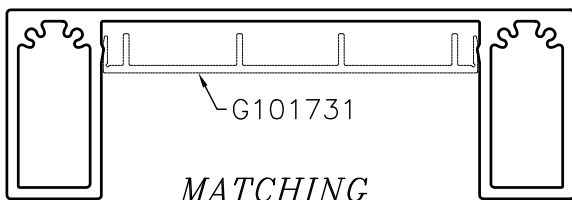
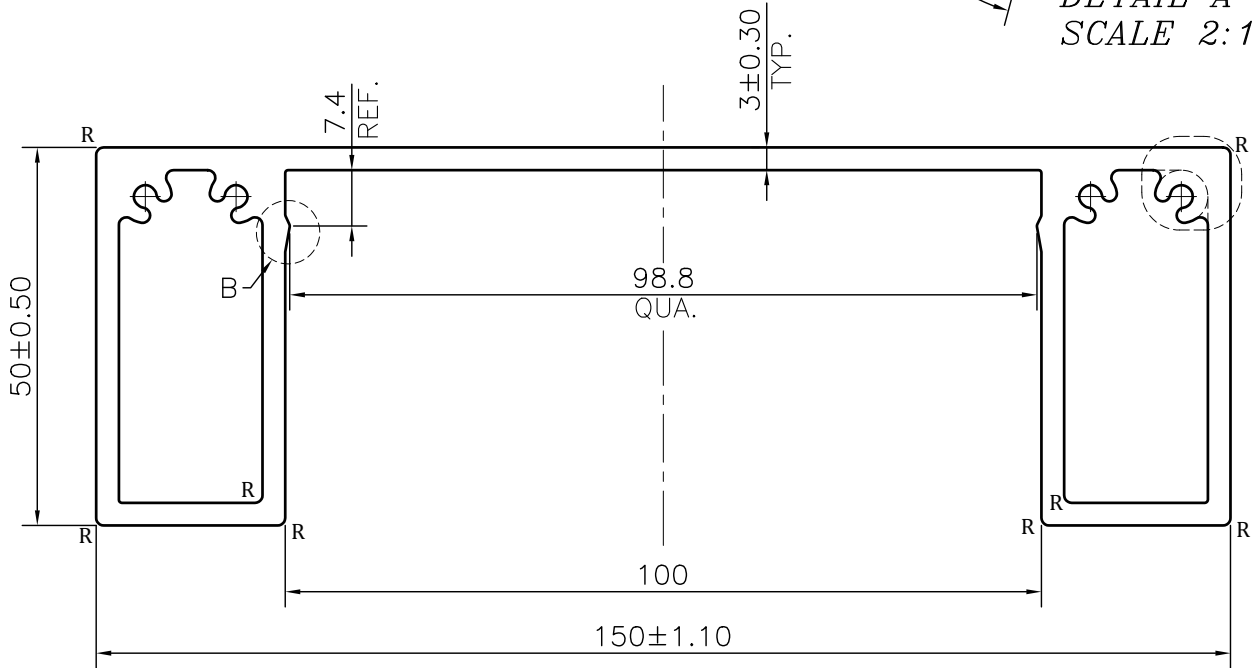

MATCHING
SCALE 1:2

NOTE:-

R= 1.0 RADIUS (16 PLACES)
F= FULL RADIUS (8 PLACES)

1. STRAIGHTNESS= 1.7mm/M
2. TWIST= 1.7mm/M
3. ANGULARITY= ±2°
4. FLATNESS= 0.007xWIDTH

Q01056

CONTROLLED COPY



SYMBOL OF QUALITY
AN ISO 9001 COMPANY

JINDAL ALUMINIUM LTD.
BHIWADI-301019 (INDIA)

| | NAME | DATE |
|----------|----------|------------|
| DRAWN | ASHUTOSH | 10-11-2023 |
| CHECKED | PARVESH | 20-12-2023 |
| APPROVED | J.N.RAI | 20-12-2023 |

1. ALL DIMENSIONS ARE IN mm.
2. ROUND OFF ALL SHARP CORNERS WITH 0.40 mm.
3. TOLERANCES WILL BE AS PER BS:EN-755-9 , UNLESS OTHERWISE SPECIFIED

| | |
|----------------------|----------|
| SCALE | 1:1 |
| AREA mm ² | 1252.222 |
| PERIMETER mm. | 491.439 |
| WEIGHT kg/m | 3.381 |

| | | |
|---------------------|---|---------------------|
| PARTY'S NAME | NITSON & AMITSU PVT. LTD., NEW DELHI | |
| PARTY'S DRAWING No. | AS PER PROPOSED DRAWING | |
| ALLOY & TEMPER | 6063 T6 | PRODUCT CODE:-056 |
| | | HSN CODE:- 76042100 |
| DESCRIPTION | ARCHITECTURAL MISC. SECTION-COVER CAP-2 FOR CW3 | |

| DRAWING No. | SECTION No. |
|-------------|-------------|
| P-JAL-B-375 | 7000001896 |
| G101733 | G101733 |