

P-JAL-B-407

G101747

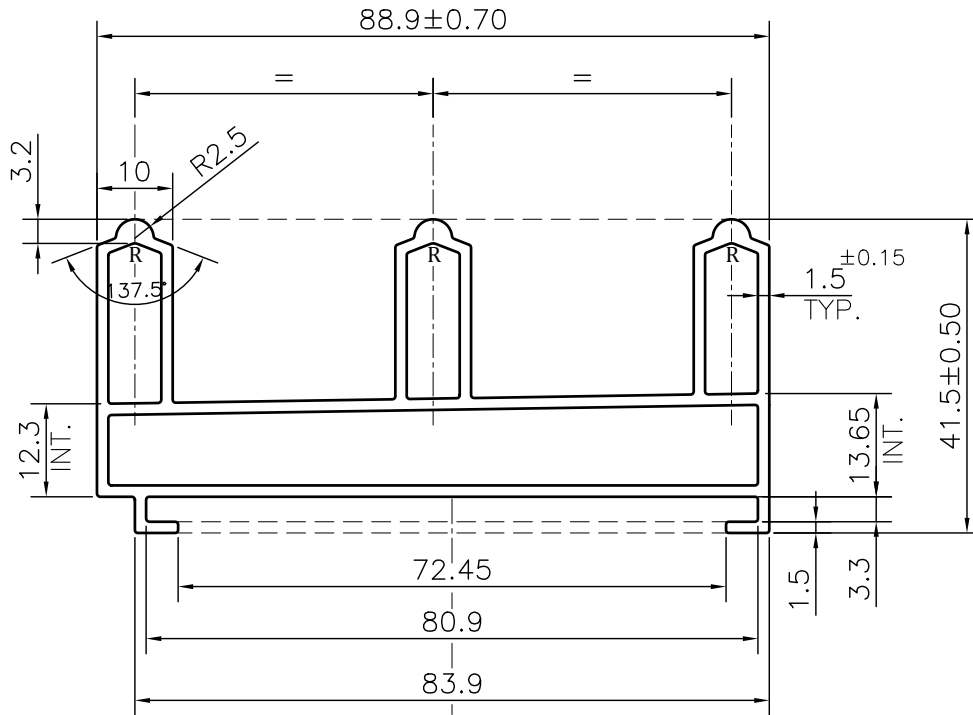

NOTE:-

R= 1.0 RADIUS (3 PLACES)

1. STRAIGHTNESS= 1.7mm/M
2. TWIST= 1.7mm/M
3. ANGULARITY= ±2°
4. FLATNESS= 0.007xWIDTH

Q01172

CONTROLLED COPY



SYMBOL OF QUALITY
AN ISO 9001 COMPANY

JINDAL ALUMINIUM LTD.
BHIWADI-301019 (INDIA)

	NAME	DATE
DRAWN	ASHUTOSH	14-12-2023
CHECKED	PARVESH	28-12-2023
APPROVED	J.N.RAI	28-12-2023
SCALE		1:1
AREA mm ²		565.046
PERIMETER mm.		367.532
WEIGHT kg/m		1.526
DRAWING No.		SECTION No.
P-JAL-B-407		7000001913
G101747		G101747

1. ALL DIMENSIONS ARE IN mm.
2. ROUND OFF ALL SHARP CORNERS WITH 0.40 mm.
3. TOLERANCES WILL BE AS PER BS:EN-755-9 , UNLESS OTHERWISE SPECIFIED

PARTY'S NAME	AASTHA ALUMINA (P) LIMITED., GURUGRAM	
PARTY'S DRAWING No.	AS PER DRAWING	
ALLOY & TEMPER	6063 T6	PRODUCT CODE:-048
		HSN CODE:- 76042100
DESCRIPTION	WINDOW SECTION	