

P-JAL-B-389-3

G101814

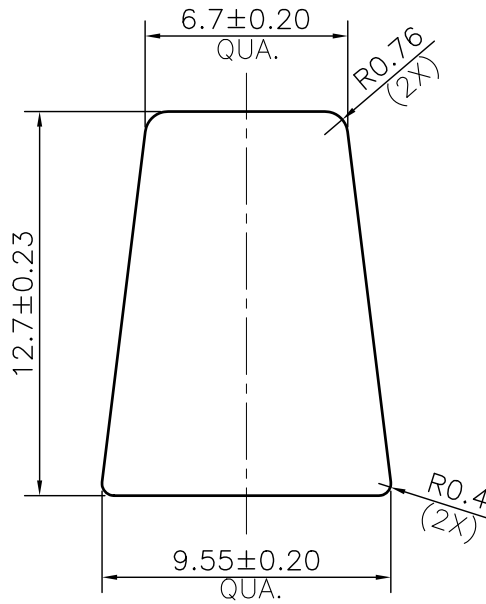

SCALE 1:1



ALLOY & TEMPER : 6063 T6 (As Per ASTM B221)

1. STRAIGHTNESS= 1.2mm/M
2. TWIST= 1.6mm/M
3. ANGULARITY= ±1.5°
4. FLATNESS= 0.006xWIDTH

Q01061

CONTROLLED COPY



SYMBOL OF QUALITY
AN ISO 9001 COMPANY

JINDAL ALUMINIUM LTD.
BHIWADI-301019 (INDIA)

	NAME	DATE
DRAWN	ASHUTOSH	04-01-2024
CHECKED	PARVESH	22-01-2024
APPROVED	J.N.RAI	22-01-2024

1. ALL DIMENSIONS ARE IN mm.
2. ROUND OFF ALL SHARP CORNERS WITH 0.40 mm.
3. TOLERANCES WILL BE AS PER ANSI H35.2(M)-2017, UNLESS OTHERWISE SPECIFIED

SCALE	4:1
AREA mm ²	102.459
PERIMETER mm.	40.83
WEIGHT kg/m	0.277

PARTY'S NAME	NEOKRAFT GLOBAL PRIVATE LIMITED, NOIDA		DRAWING No.	SECTION No.
PARTY'S DRAWING No.	AS PER DRAWING		P-JAL-B-389-3	7000001977
ALLOY & TEMPER	6063 T6 as per ASTM B221	PRODUCT CODE:-005	G101814	G101814
		HSN CODE:- 76042990		
DESCRIPTION	MISC. BAR SECTION			