

P-JAL-B-425
G101823

EXPOSED SURFACE G101824

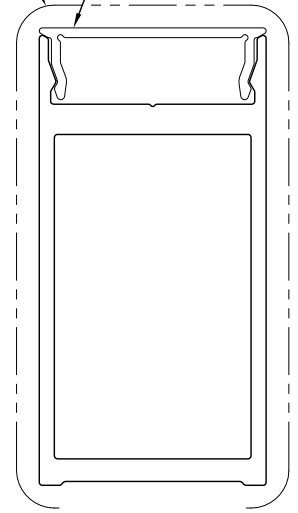

SCALE 1:1

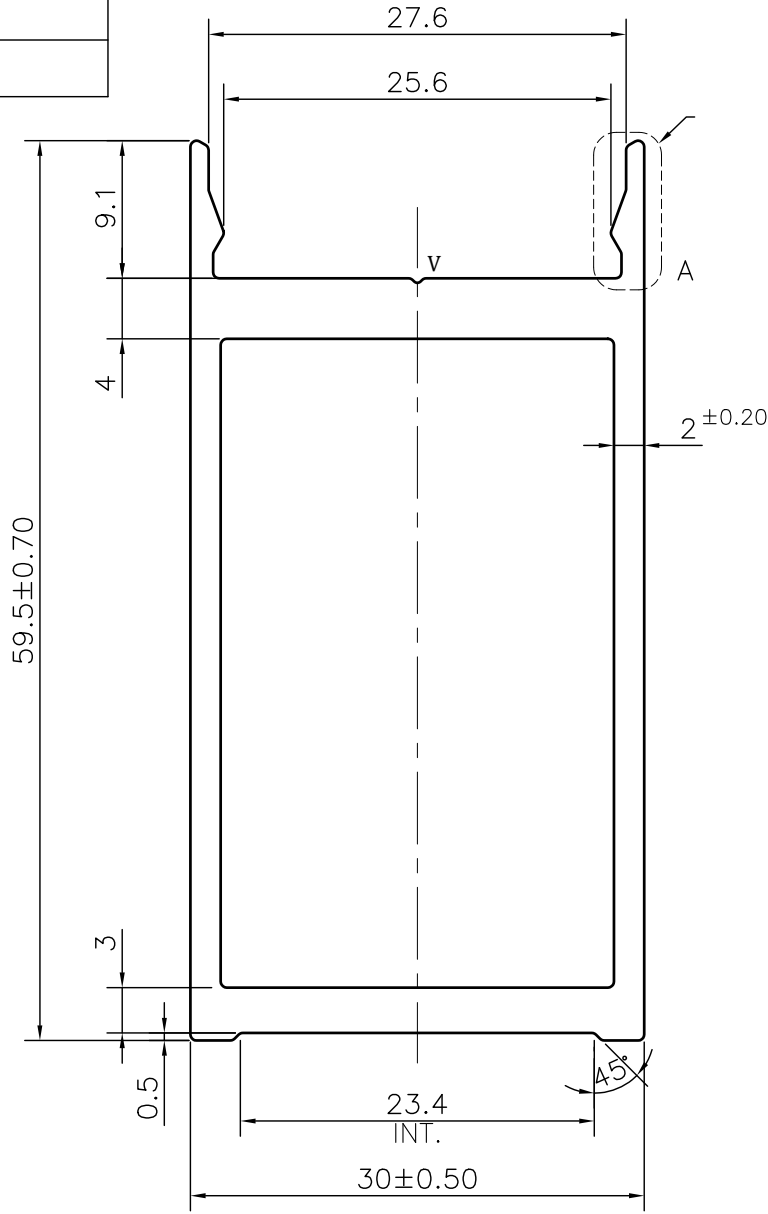
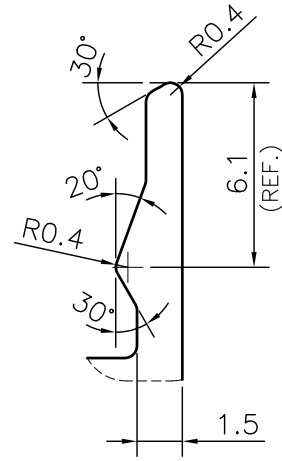

DETAIL A
SCALE 4:1

NOTE:-
V= 0.3x90° V-GROOVE (1 PLACE)

1. STRAIGHTNESS= 1.7mm/M
2. TWIST= 1.7mm/M
3. ANGULARITY= ±2°
4. FLATNESS= 0.007xWIDTH

Q01154
CONTROLLED COPY

 SYMBOL OF QUALITY AN ISO 9001 COMPANY	JINDAL ALUMINIUM LTD. BHIWADI-301019 (INDIA)		NAME	DATE	
			DRAWN	ASHUTOSH	28-12-2023
1. ALL DIMENSIONS ARE IN mm. 2. ROUND OFF ALL SHARP CORNERS WITH 0.40 mm. 3. TOLERANCES WILL BE AS PER BS:EN-755-9 , UNLESS OTHERWISE SPECIFIED			CHECKED	PARVESH	25-01-2024
			APPROVED	J.N.RAI	25-01-2024
PARTY'S NAME GSC ALUSYSTEMS PRIVATE LIMITED, GREATER NOIDA			SCALE		2:1
			AREA mm ²		411.782
PARTY'S DRAWING No. AS PER DRAWING-M33558			PERIMETER mm.		196.124
			WEIGHT kg/m		1.112
ALLOY & TEMPER 6063 T6			DRAWING No.	SECTION No.	
			P-JAL-B-425		7000001992
DESCRIPTION ARCHITECTURAL MISC. SECTION			G101823		G101823
			PRODUCT CODE:-056		
			HSN CODE:- 76042100		