

P-JAL-B-440

G101908

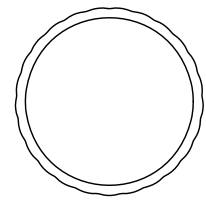

SCALE 1:1

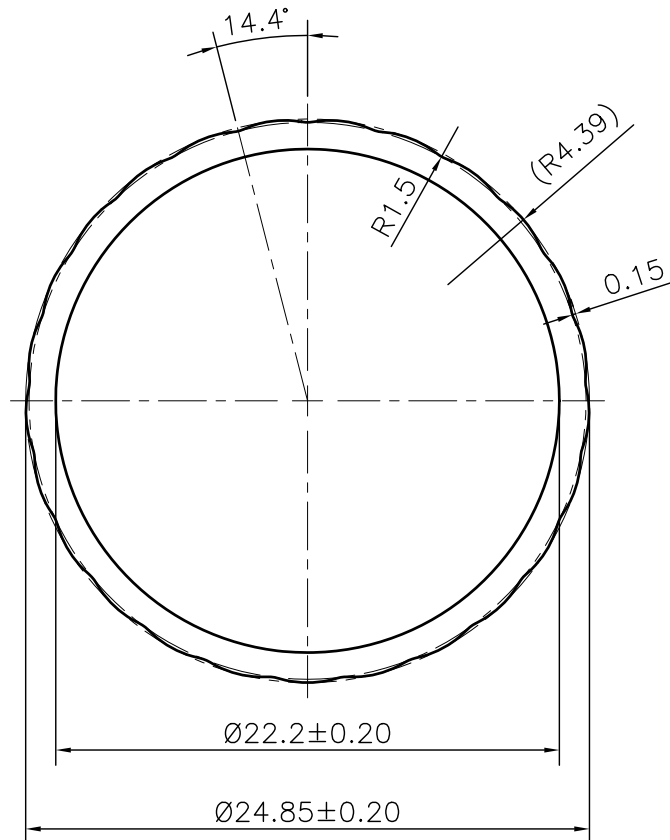

25 FLUTES

1. STRAIGHTNESS= 1.7mm/M
2. TWIST= 1.7mm/M
3. ANGULARITY= $\pm 2^\circ$
4. FLATNESS= 0.007xWIDTH

Q01362

CONTROLLED COPY



SYMBOL OF QUALITY
AN ISO 9001 COMPANY

JINDAL ALUMINIUM LTD.
BHIWADI-301019 (INDIA)

	NAME	DATE
DRAWN	ASHUTOSH	01-02-2024
CHECKED	PARVESH	19-02-2024
APPROVED	J.N.RAI	19-02-2024
SCALE		3:1
AREA mm ²		93.393
PERIMETER mm.		78.184
WEIGHT kg/m		0.252
DRAWING No.		SECTION No.
P-JAL-B-440		7000002076
G101908		G101908

1. ALL DIMENSIONS ARE IN mm.
2. ROUND OFF ALL SHARP CORNERS WITH 0.40 mm.
3. TOLERANCES WILL BE AS PER BS:EN-755-9 , UNLESS OTHERWISE SPECIFIED

PARTY'S NAME	UNGER INDIA PVT. LTD., GURGAON	
PARTY'S DRAWING No.	AS PER SAMPLE	
ALLOY & TEMPER	6063 T6	PRODUCT CODE:-011
		HSN CODE:- 76042100
DESCRIPTION	FLUTED ROUND TUBE	