

P-JAL-B-453

G102223

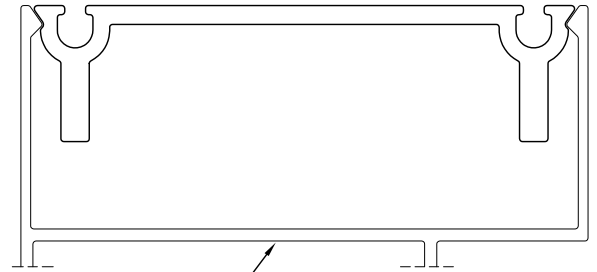

G102224
G102225

**MATCHING
SCALE 1:1**

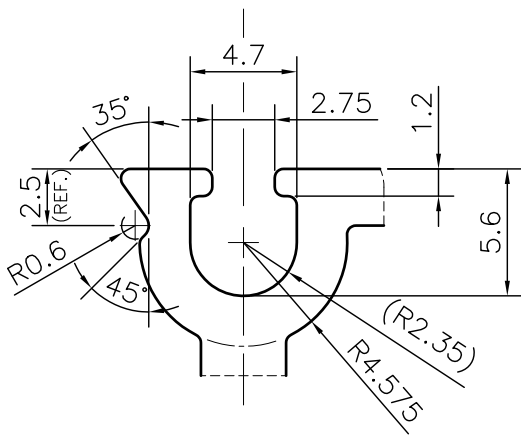

**DETAIL A
SCALE 3:1**

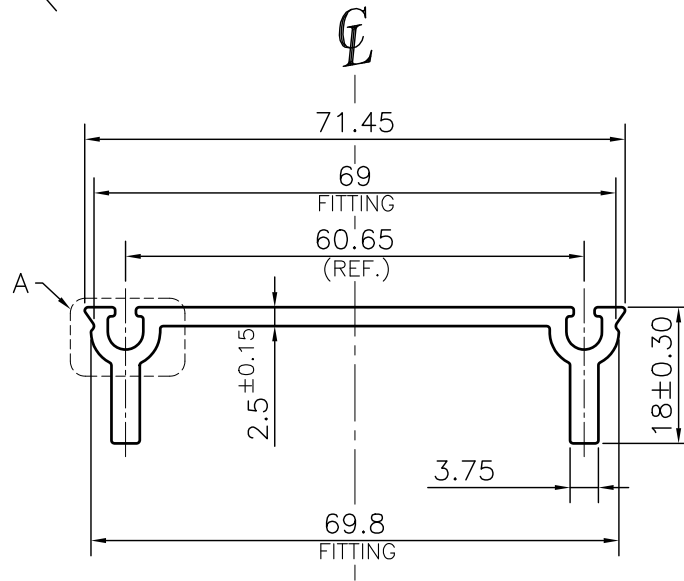

TOLERANCE CHART CD = CIRCUMSCRIBING CIRCLE

DIMENSION	CD<100	100<CD<200	200<CD<300	300<CD<500
UPTO 10mm	±0.25	±0.30	±0.35	±0.40
10.0 - 25.0	±0.30	±0.40	±0.50	±0.60
25.0 - 50.0	±0.50	±0.60	±0.80	±0.90
50.0 - 100	±0.70	±0.90	±1.10	±1.30
100 - 150	-	±1.10	±1.30	±1.50
150 - 200	-	±1.3	±1.50	±1.80
200 - 300	-	-	±1.70	±2.10
300 - 450	-	-	-	±2.80

Q01429

CONTROLLED COPY

1. STRAIGHTNESS= 1.7mm/M
2. TWIST= 1.7mm/M
3. ANGULARITY= ±2°
4. FLATNESS= 0.007xWIDTH



SYMBOL OF QUALITY
AN ISO 9001 COMPANY

JINDAL ALUMINIUM LTD.
BHIWADI-301019 (INDIA)

	NAME	DATE
DRAWN	ASHUTOSH	12-03-2024
CHECKED	PARVESH	11-05-2024
APPROVED	J.N RAI	13-05-2024

1. ALL DIMENSIONS ARE IN mm.
2. ROUND OFF ALL SHARP CORNERS WITH 0.40 mm.
3. TOLERANCES WILL BE AS PER BS:EN-755-9 , UNLESS OTHERWISE SPECIFIED

SCALE	1:1
AREA mm ²	288.976
PERIMETER mm.	225.27
WEIGHT kg/m	0.780

PARTY'S NAME	KSV INFRABUILD- FARIDABAD	
PARTY'S DRAWING No.	AS PER DRAWING-KSV IOCL N-01	
ALLOY & TEMPER	6063 T6	PRODUCT CODE:-055
		HSN CODE:- 76042990
DESCRIPTION	CURTAIN WALL SECTION- PRESSURE PLATE	

DRAWING No.	SECTION No.
P-JAL-B-453	7000002411
G102223	G102223