

P-JAL-B-482-1
G102232

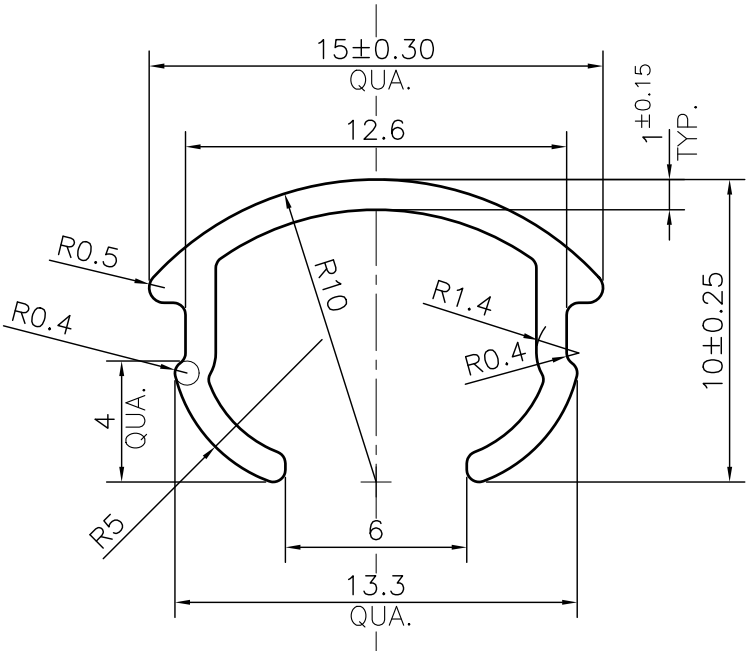
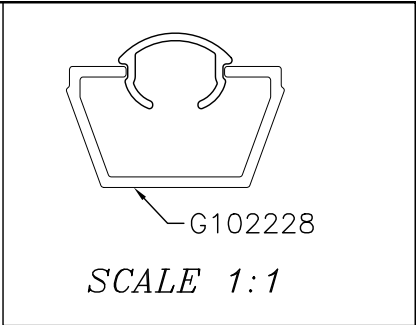

TOLERANCE CHART CD = CIRCUMSCRIBING CIRCLE

DIMENSION	CD<100	100<CD<200	200<CD<300	300<CD<500
UPTO 10mm	±0.25	±0.30	±0.35	±0.40
10.0 -25.0	±0.30	±0.40	±0.50	±0.60
25.0 -50.0	±0.50	±0.60	±0.80	±0.90
50.0 -100	±0.70	±0.90	±1.10	±1.30
100 - 150	-	±1.10	±1.30	±1.50
150 - 200	-	±1.3	±1.50	±1.80
200 - 300	-	-	±1.70	±2.10
300 - 450	-	-	-	±2.80

Q01696
CONTROLLED COPY

1. STRAIGHTNESS= 1.7mm/M
2. TWIST= 1.7mm/M
3. ANGULARITY= ±2°
4. FLATNESS= 0.007xWIDTH

 SYMBOL OF QUALITY AN ISO 9001 COMPANY	JINDAL ALUMINIUM LTD. BHIWADI-301019 (INDIA)		NAME	DATE	
			DRAWN	ASHUTOSH	02-05-2024
1. ALL DIMENSIONS ARE IN mm. 2. ROUND OFF ALL SHARP CORNERS WITH 0.40 mm. 3. TOLERANCES WILL BE AS PER BS:EN-755-9 , UNLESS OTHERWISE SPECIFIED			CHECKED	PARVESH	15-05-2024
			APPROVED	J.N.RAI	15-05-2024
PARTY'S NAME WINDOOR TECH, GURUGRAM			SCALE		4:1
			AREA mm ²		32.879
PARTY'S DRAWING No. MESH FITTING (AS PER CUSTOMER REQUIREMENT.)			PERIMETER mm.		63.61
			WEIGHT kg/m		0.089
ALLOY & TEMPER 6063 T6			DRAWING No.	SECTION No.	
			P-JAL-B-482-1	G102232	
DESCRIPTION WINDOW SECTION			PRODUCT CODE:-048		
			HSN CODE:- 76042990		