

P-JAL-B-457-1
G102298

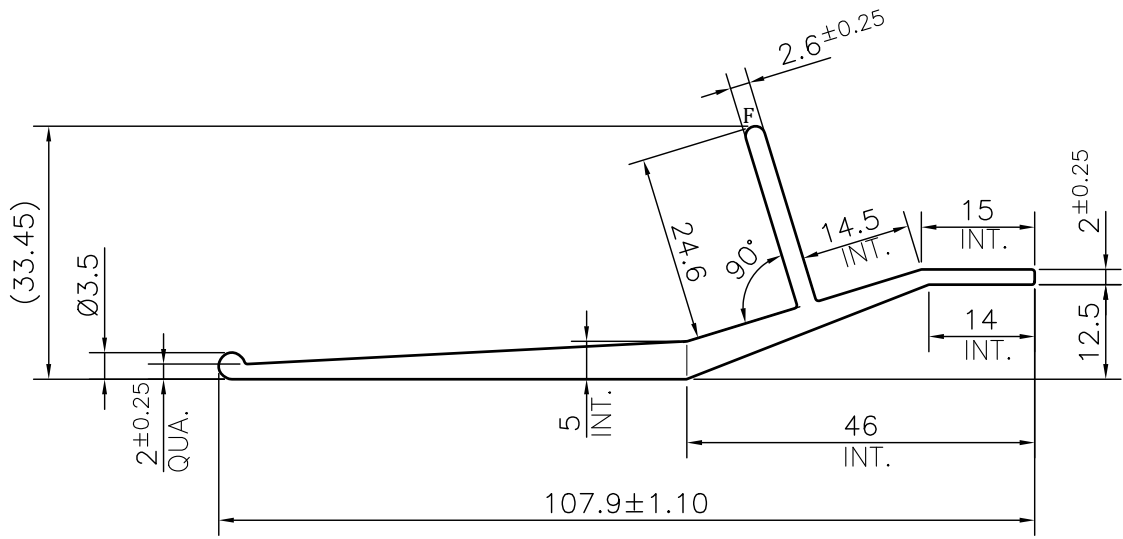

TOLERANCE CHART CD = CIRCUMSCRIBING CIRCLE

DIMENSION	CD≤100	100<CD≤200	200<CD≤300	300<CD≤500
UP TO 10mm	±0.25	±0.30	±0.35	±0.40
10.0 -25.0	±0.30	±0.40	±0.50	±0.60
25.0 -50.0	±0.50	±0.60	±0.80	±0.90
50.0 -100	±0.70	±0.90	±1.10	±1.30
100 - 150	-	±1.10	±1.30	±1.50
150 - 200	-	±1.3	±1.50	±1.80
200 - 300	-	-	±1.70	±2.10
300 - 450	-	-	-	±2.80

Q01453

UNCONTROLLED COPY

NOTE:-

F= FULL RADIUS (1 PLACE)

1. STRAIGHTNESS= 1.7mm/M
2. TWIST= 1.7mm/M
3. ANGULARITY= ±2°
4. FLATNESS= 0.007xWIDTH

1) THE WELDING LINE IN THE EXPOSED SURFACE OF PROFILE IS UNAVOIDABLE. 2) PLEASE SPECIFY IMPORTANT SIZES. 3) PLEASE SPECIFY IF THIS PROFILE MATCHES WITH OTHER PROFILES. 4) PLEASE SPECIFY EXPOSED SURFACE. OTHER WISE CONSIDERED AS NO EXPOSED SURFACE. 5) FINISH :- MILL FINISH / ANODIZING / POWDER COATING

 SYMBOL OF QUALITY AN ISO 9001 COMPANY	JINDAL ALUMINIUM LTD. <i>BHIWADI-301019 (INDIA)</i>	NAME	DATE	
		DRAWN	ASHUTOSH	02-05-2024
		CHECKED	PARVESH	03-06-2024
		APPROVED	J.N.RAI	03-06-2024
1. ALL DIMENSIONS ARE IN mm. 2. ROUND OFF ALL SHARP CORNERS WITH 0.40 mm. 3. TOLERANCES WILL BE AS PER BS:EN-755-9 , UNLESS OTHERWISE SPECIFIED		SCALE	1:1	
		AREA mm ²	422.218	
		PERIMETER mm.	271.71	
		WEIGHT kg/m	1.140	
PARTY'S NAME	AAREN EXPORT	DRAWING No.	SECTION No.	
PARTY'S DRAWING No.	AS PER PROPOSAL DRAWING (AE-571)	P-JAL-B-457-1	7000002474	
ALLOY & TEMPER	6005 T6	G102298	G102298	
PRODUCT CODE:-	087			
DESCRIPTION	GENERAL MISC. SECTION	HSN CODE:-	76042990	