

P-JAL-B-535-3

G102306

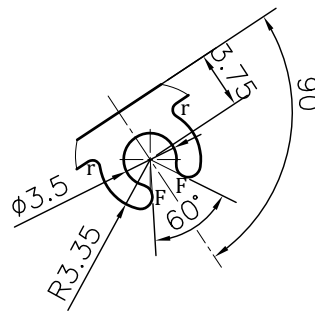

DETAIL A  
SCALE 2:1

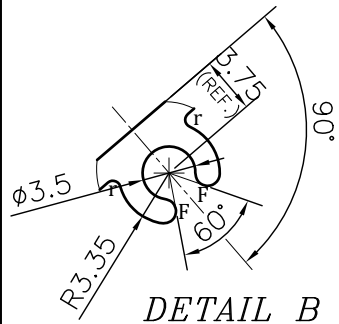
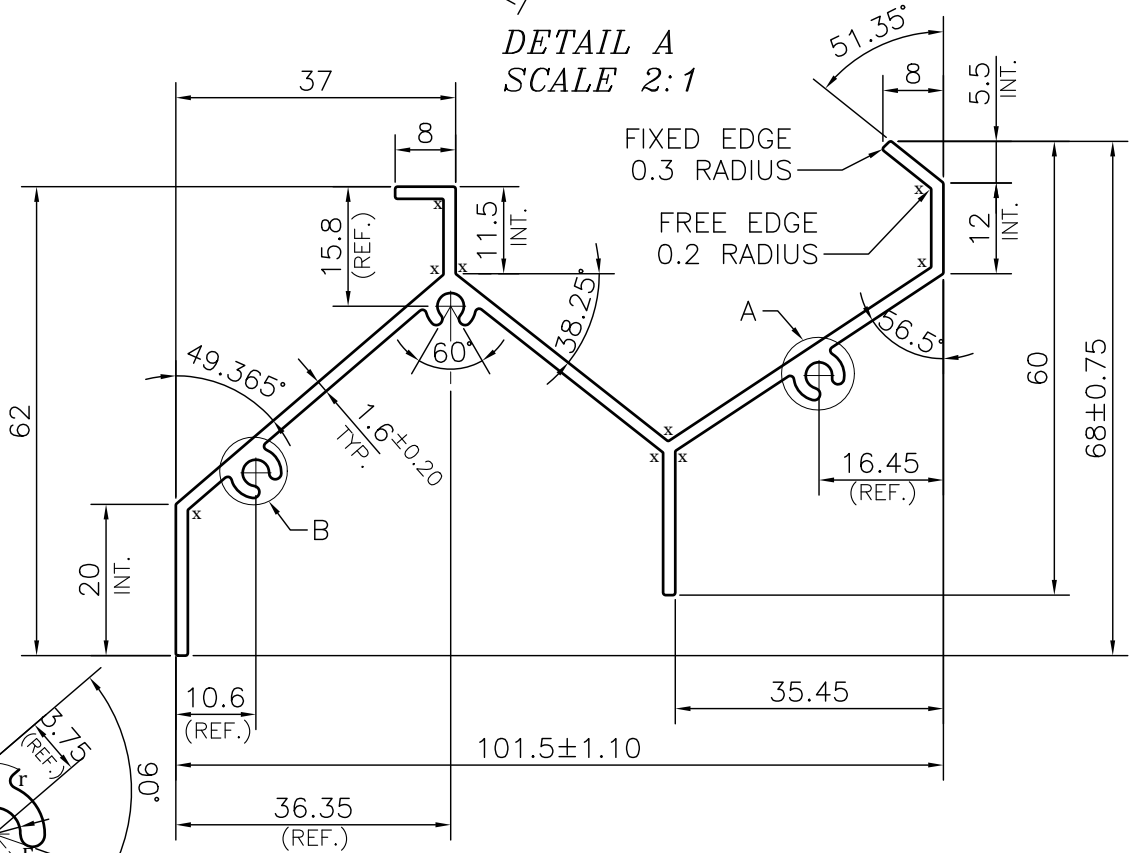

DETAIL B  
SCALE 2:1

FIXED EDGE  
0.3 RADIUS  
FREE EDGE  
0.2 RADIUS

**NOTE:-**

- x= 0.20 RADIUS (9 PLACES)**
- r= 0.50 RADIUS (6 PLACES)**
- F= FULL RADIUS (6 PLACES)**

TOLERANCE CHART CD = CIRCUMSCRIBING CIRCLE

DIMENSION	CD<100	100<CD<200	200<CD<300	300<CD<500
UPTO 10mm	±0.25	±0.30	±0.35	±0.40
10.0 -25.0	±0.30	±0.40	±0.50	±0.60
25.0 -50.0	±0.50	±0.60	±0.80	±0.90
50.0 -100	±0.70	±0.90	±1.10	±1.30
100 - 150	-	±1.10	±1.30	±1.50
150 - 200	-	±1.3	±1.50	±1.80
200 - 300	-	-	±1.70	±2.10
300 - 450	-	-	-	±2.80

ROUND OFF ALL SHARP CORNERS WITH 0.30 mm.

Q01846

CONTROLLED COPY

1. STRAIGHTNESS= 1.7mm/M
2. TWIST= 1.7mm/M
3. ANGULARITY= ±2°
4. FLATNESS= 0.007xWIDTH



SYMBOL OF QUALITY  
AN ISO 9001 COMPANY

**JINDAL ALUMINIUM LTD.**  
BHIWADI-301019 (INDIA)

	NAME	DATE
DRAWN	ASHUTOSH	27-05-2024
CHECKED	PARVESH	06-06-2024
APPROVED	J.N.RAI	08-06-2024

1. ALL DIMENSIONS ARE IN mm.
2. ROUND OFF ALL SHARP CORNERS WITH 0.30 mm.
3. TOLERANCES WILL BE AS PER BS:EN-755-9 , UNLESS OTHERWISE SPECIFIED

SCALE	1:1
AREA mm <sup>2</sup>	369.79
PERIMETER mm.	445.8
WEIGHT kg/m	0.998
DRAWING No.	SECTION No.
P-JAL-B-535-3	7000002481
G102306	G102306

PARTY'S NAME	GO ALUBUILD PVT. LTD, BAWAL	
PARTY'S DRAWING No.	AS PER PROPOSAL DRAWING	
ALLOY & TEMPER	6063 T6	PRODUCT CODE:-048
		HSN CODE:- 76042990
DESCRIPTION	LOUVER SECTION-' Y ' TYPE LOUVER-R1	