

P-JAL-B-538-1

G102309

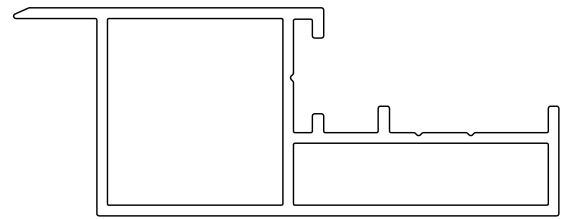

SCALE 1:1

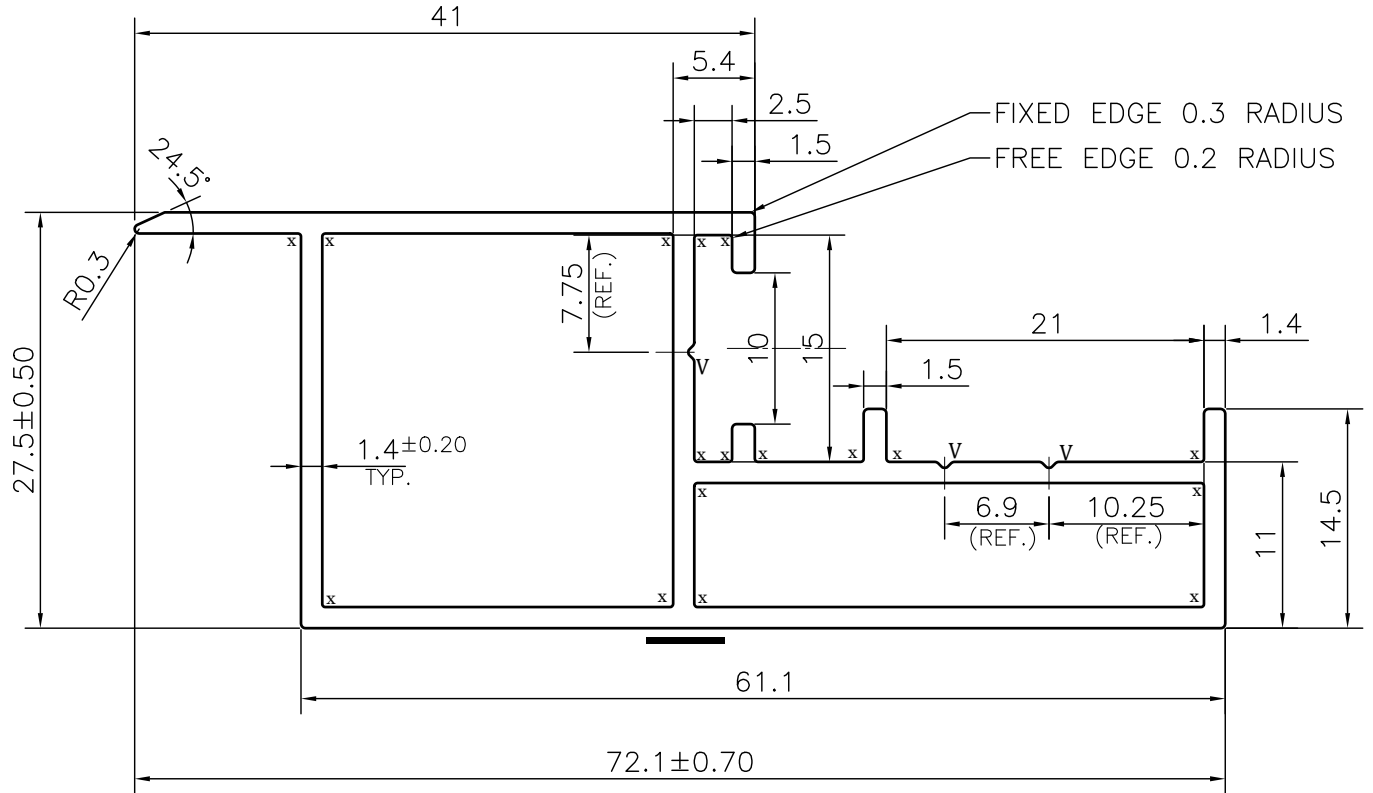

**PLEASE NOTE:-**  
 — DUE TO THICKNESS VARIATION  
 IMPRESSION MARK MAY APPEAR  
 IN THIS MARKED PORTION.

**NOTE:-**  
**x= 0.20 RADIUS (17 PLACES)**  
**V= 0.4x90° V-GROOVE (3 PLACES)**

TOLERANCE CHART CD = CIRCUMSCRIBING CIRCLE

DIMENSION	CD<100	100<CD<200	200<CD<300	300<CD<500
UPTO 10mm	±0.25	±0.30	±0.35	±0.40
10.0 -25.0	±0.30	±0.40	±0.50	±0.60
25.0 -50.0	±0.50	±0.60	±0.80	±0.90
50.0 -100	±0.70	±0.90	±1.10	±1.30
100 - 150	-	±1.10	±1.30	±1.50
150 - 200	-	±1.3	±1.50	±1.80
200 - 300	-	-	±1.70	±2.10
300 - 450	-	-	-	±2.80

☞ ROUND OFF ALL SHARP CORNERS WITH 0.30 mm.

Q01849  
 CONTROLLED COPY

1. STRAIGHTNESS= 1.7mm/M
2. TWIST= 1.7mm/M
3. ANGULARITY= ±2°
4. FLATNESS= 0.007xWIDTH

 SYMBOL OF QUALITY AN ISO 9001 COMPANY	<b>JINDAL ALUMINIUM LTD.</b> BHIWADI-301019 (INDIA)		NAME	DATE	
			DRAWN	ASHUTOSH	27-05-2024
1. ALL DIMENSIONS ARE IN mm. 2. ROUND OFF ALL SHARP CORNERS WITH 0.30 mm. 3. TOLERANCES WILL BE AS PER BS:EN-755-9 , UNLESS OTHERWISE SPECIFIED			CHECKED	PARVESH	06-06-2024
			APPROVED	J.N.RAI	08-06-2024
PARTY'S NAME GO ALUBUILD PVT. LTD, BAWAL			SCALE		2:1
			AREA mm <sup>2</sup>		288.997
PARTY'S DRAWING No. AS PER CAD DRAWING			PERIMETER mm.		228.966
			WEIGHT kg/m		0.780
ALLOY & TEMPER 6063 T6			DRAWING No.		P-JAL-B-538-1
			SECTION No.		
DESCRIPTION CURTAIN WALL SECTION (6 & 8 MM THICK GLASS FRAME-R0)			G102309		G102309
			PRODUCT CODE:-055		
HSN CODE:- 76042100					