

P-JAL-B-505

G102336

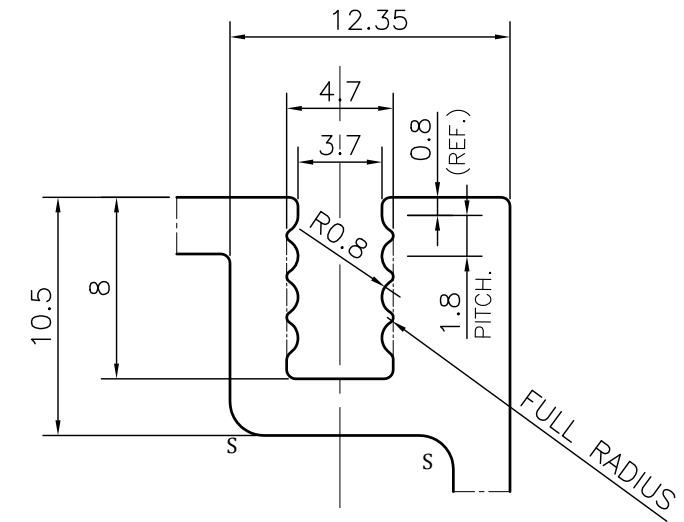

DETAIL A
SCALE 3:1

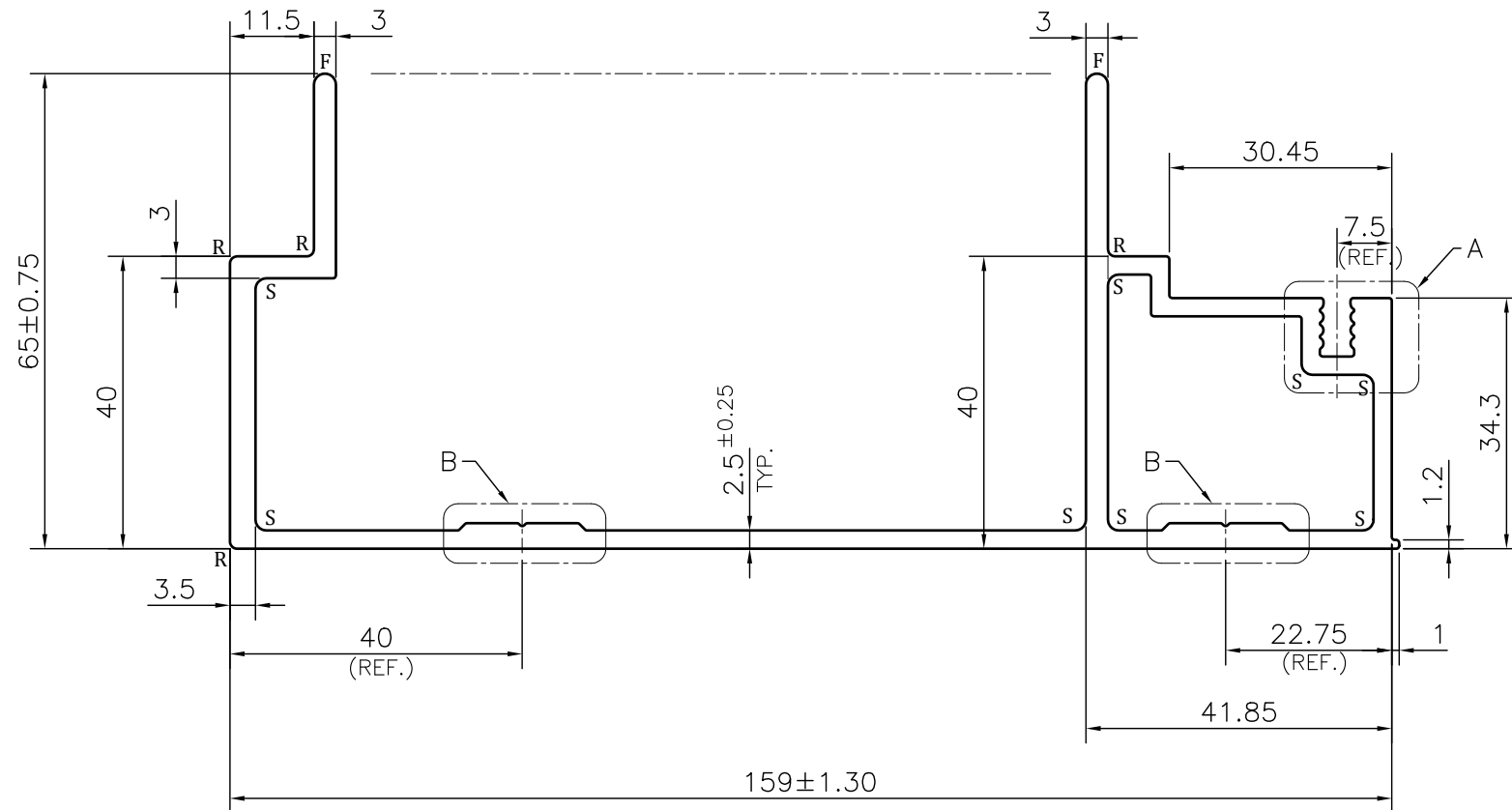
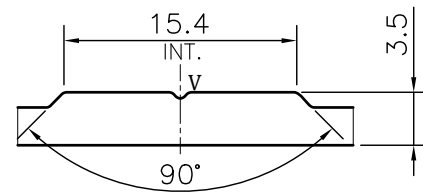

DETAIL B
SCALE 2:1

NOTE:-
R= 1.0 RADIUS (4 PLACES)
S= 1.5 RADIUS (8 PLACES)
F= FULL RADIUS (2 PLACES)
V= 0.4x90° V-GROOVE (2 PLACES)

1. STRAIGHTNESS= 1.7mm/M
2. TWIST= 1.7mm/M
3. ANGULARITY= ±2°
4. FLATNESS= 0.007xWIDTH

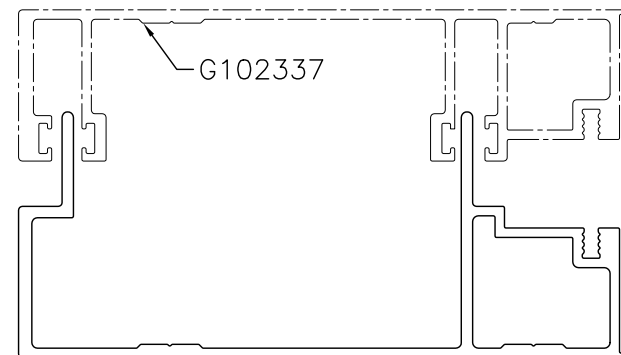

MATCHING
SCALE 1:2

TOLERANCE CHART CD = CIRCUMSCRIBING CIRCLE				
DIMENSION	CD≤100	100<CD≤200	200<CD≤300	300<CD≤500
UPTO 10mm	±0.25	±0.30	±0.35	±0.40
10.0 - 25.0	±0.30	±0.40	±0.50	±0.60
25.0 - 50.0	±0.50	±0.60	±0.80	±0.90
50.0 - 100	±0.70	±0.90	±1.10	±1.30
100 - 150	-	±1.10	±1.30	±1.50
150 - 200	-	±1.3	±1.50	±1.80
200 - 300	-	-	±1.70	±2.10
300 - 450	-	-	-	±2.80

Q01558

CONTROLLED COPY



SYMBOL OF QUALITY
AN ISO 9001 COMPANY

JINDAL ALUMINIUM LTD.
BHIWADI-301019 (INDIA)

1. ALL DIMENSIONS ARE IN mm.
2. ROUND OFF ALL SHARP CORNERS WITH 0.40 mm.
3. TOLERANCES WILL BE AS PER BS:EN-755-9 , UNLESS OTHERWISE SPECIFIED

PARTY'S NAME: AASTHA ALUMINA (P) LIMITED, GURUGRAM

PARTY'S DRAWING No.: AA-AA13-MM-01

ALLOY & TEMPER: 6063 T6

PRODUCT CODE:-055
HSN CODE:- 76042100

DESCRIPTION: CURTAIN WALL SECTION-MALE MULLION

	NAME	DATE
DRAWN	ASHUTOSH	10-05-2024
CHECKED	PARVESH	13-06-2024
APPROVED	J.N. RAI	13-06-2024
SCALE	1:1	
AREA	mm ²	1089.007
PERIMETER	mm.	609.337
WEIGHT	kg/m	2.940
DRAWING No.	SECTION No.	
P-JAL-B-505	700002507	
G102336	G102336	