

P-JAL-B-558

G102419

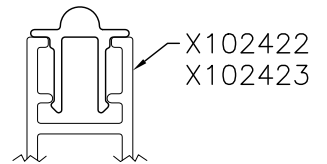

SCALE 1:1

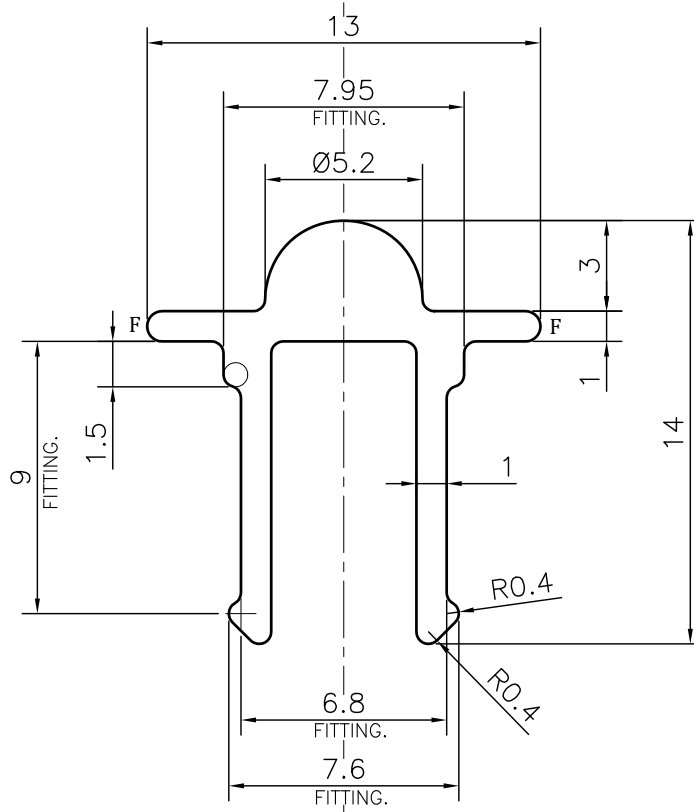

TOLERANCE CHART CD = CIRCUMSCRIBING CIRCLE

| DIMENSION | CD<100 | 100<CD<200 | 200<CD<300 | 300<CD<500 |
|------------|--------|------------|------------|------------|
| UPTO 10mm | ±0.25 | ±0.30 | ±0.35 | ±0.40 |
| 10.0 -25.0 | ±0.30 | ±0.40 | ±0.50 | ±0.60 |
| 25.0 -50.0 | ±0.50 | ±0.60 | ±0.80 | ±0.90 |
| 50.0 -100 | ±0.70 | ±0.90 | ±1.10 | ±1.30 |
| 100 - 150 | - | ±1.10 | ±1.30 | ±1.50 |
| 150 - 200 | - | ±1.3 | ±1.50 | ±1.80 |
| 200 - 300 | - | - | ±1.70 | ±2.10 |
| 300 - 450 | - | - | - | ±2.80 |

Q01828

CONTROLLED COPY

NOTE:-

F= FULL RADIUS (2 PLACES)

1. STRAIGHTNESS= 1.7mm/M
2. TWIST= 1.7mm/M
3. ANGULARITY= ±2°
4. FLATNESS= 0.007xWIDTH



SYMBOL OF QUALITY
AN ISO 9001 COMPANY

JINDAL ALUMINIUM LTD.
BHIWADI-301019 (INDIA)

| | NAME | DATE |
|----------------------|-------------|------------|
| DRAWN | ASHUTOSH | 30-05-2024 |
| CHECKED | PARVESH | 02-07-2024 |
| APPROVED | N.K.HOLEY | 03-07-2024 |
| SCALE | | 4:1 |
| AREA mm ² | | 47.695 |
| PERIMETER mm. | | 68.95 |
| WEIGHT kg/m | | 0.129 |
| DRAWING No. | SECTION No. | |
| P-JAL-B-558 | 7000002570 | |
| G102419 | G102419 | |

1. ALL DIMENSIONS ARE IN mm.
2. ROUND OFF ALL SHARP CORNERS WITH 0.40 mm.
3. TOLERANCES WILL BE AS PER BS:EN-755-9 , UNLESS OTHERWISE SPECIFIED

| | | |
|---------------------|--|---------------------|
| PARTY'S NAME | WINDOOR TECH, GURUGRAM | |
| PARTY'S DRAWING No. | (AS PER CUSTOMER REQUIREMENT) | |
| ALLOY & TEMPER | 6063 T6 | PRODUCT CODE:-048 |
| | | HSN CODE:- 76042990 |
| DESCRIPTION | WINDOW SECTION-RAIL TRACK-25 MM SERIES | |