

P-JAL-B-559

G102420

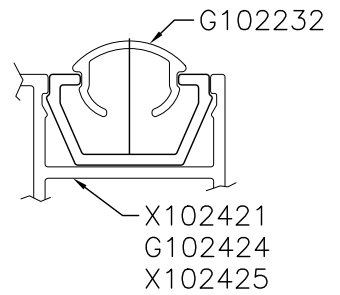

SCALE 1:1

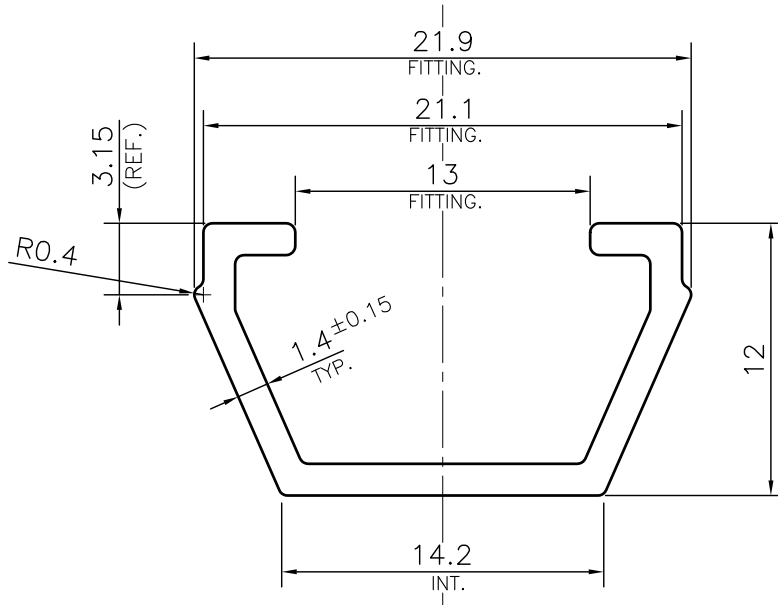

TOLERANCE CHART CD = CIRCUMSCRIBING CIRCLE

DIMENSION	CD<100	100<CD<200	200<CD<300	300<CD<500
UPTO 10mm	±0.25	±0.30	±0.35	±0.40
10.0 - 25.0	±0.30	±0.40	±0.50	±0.60
25.0 - 50.0	±0.50	±0.60	±0.80	±0.90
50.0 - 100	±0.70	±0.90	±1.10	±1.30
100 - 150	-	±1.10	±1.30	±1.50
150 - 200	-	±1.3	±1.50	±1.80
200 - 300	-	-	±1.70	±2.10
300 - 450	-	-	-	±2.80

Q01829

CONTROLLED COPY

1. STRAIGHTNESS= 1.7mm/M
2. TWIST= 1.7mm/M
3. ANGULARITY= ±2°
4. FLATNESS= 0.007xWIDTH



SYMBOL OF QUALITY
AN ISO 9001 COMPANY

JINDAL ALUMINIUM LTD.
BHIWADI-301019 (INDIA)

	NAME	DATE
DRAWN	ASHUTOSH	30-05-2024
CHECKED	PARVESH	02-07-2024
APPROVED	N.K.HOLEY	03-07-2024

1. ALL DIMENSIONS ARE IN mm.
2. ROUND OFF ALL SHARP CORNERS WITH 0.40 mm.
3. TOLERANCES WILL BE AS PER BS:EN-755-9 , UNLESS OTHERWISE SPECIFIED

SCALE	3:1
AREA mm ²	60.116
PERIMETER mm.	86.7
WEIGHT kg/m	0.162

PARTY'S NAME	WINDOOR TECH, GURUGRAM	DRAWING No.	P-JAL-B-559	SECTION No.	7000002601
PARTY'S DRAWING No.	AS PER CAD DRAWING		G102420		G102420
ALLOY & TEMPER	6063 T6	PRODUCT CODE:-048			
		HSN CODE:- 76042990			
DESCRIPTION	WINDOW SECTION-GLOSS ADAPTER-25 MM SERIES				