

P-JAL-B-610

G102433

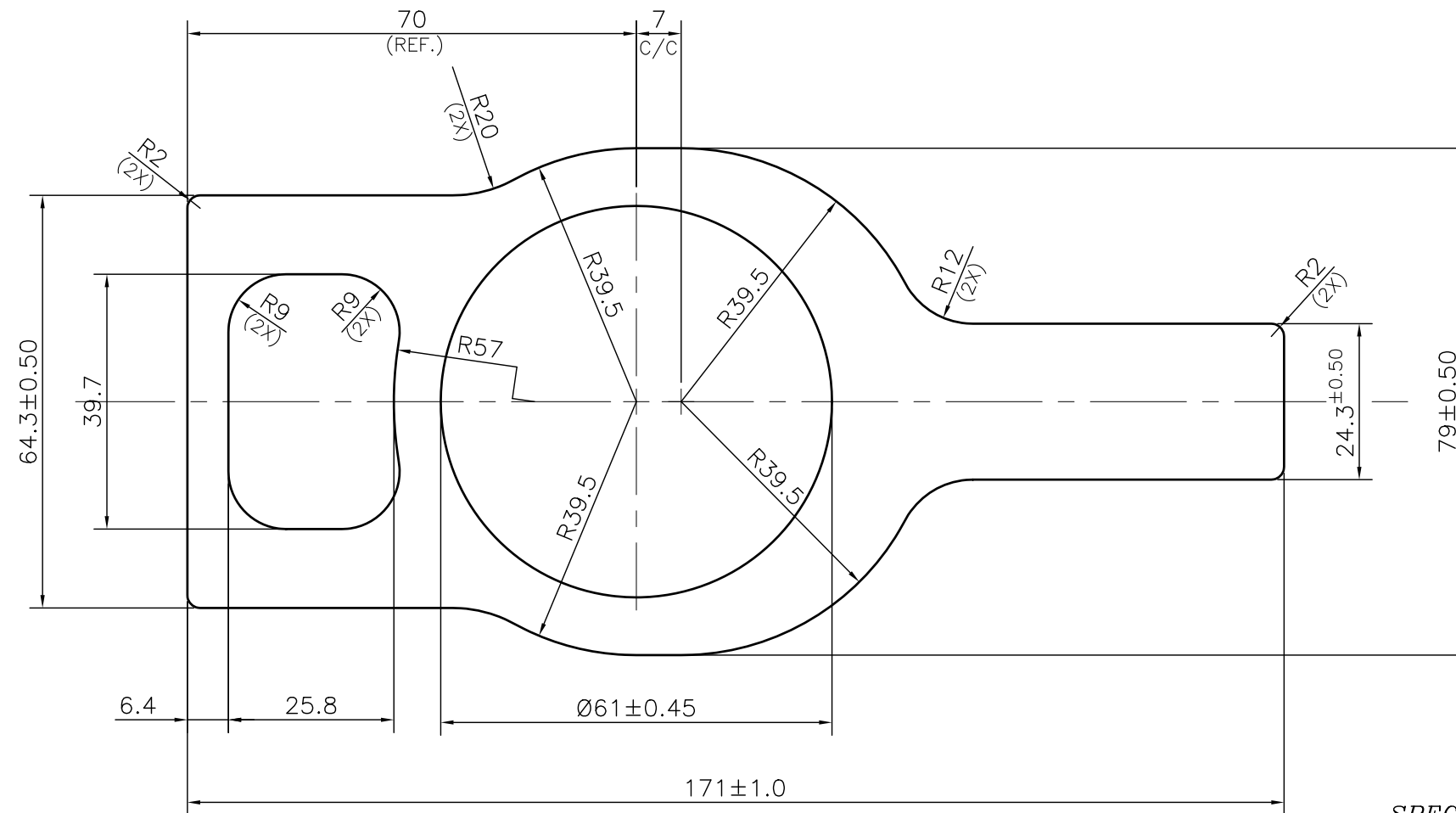

SPECIAL NOTE:-
 PART SHOULD BE FREE FROM BURR,
 DENT, SCRATCH AND CUT MARKS.

1. STRAIGHTNESS= 1.7mm/M
2. TWIST= 1.7mm/M
3. ANGULARITY= ±2°
4. FLATNESS= 0.007xWIDTH

Q01587

CONTROLLED COPY



SYMBOL OF QUALITY
 AN ISO 9001 COMPANY

JINDAL ALUMINIUM LTD.
 BHIWADI-301019 (INDIA)

1. ALL DIMENSIONS ARE IN mm.
2. ROUND OFF ALL SHARP CORNERS WITH 0.40 mm.
3. TOLERANCES WILL BE AS PER BS:EN-755-9 , UNLESS OTHERWISE SPECIFIED

PARTY'S NAME

STORK RUBBER PRODUCTS , GURGAON

PARTY'S DRAWING No.

AS PER DRAWING-1301288

ALLOY & TEMPER

6082 T6

PRODUCT CODE:-085

HSN CODE:- 76042100

DESCRIPTION

AUTOMOBILE SECTION - AL BRACKET

	NAME	DATE
DRAWN	ASHUTOSH	14-06-2024
CHECKED	PARVESH	02-07-2024
APPROVED	N.K.HOLEY	02-07-2024
SCALE		1:1
AREA	mm ²	5195.366
PERIMETER	mm.	450.195
WEIGHT	kg/m	14.027
DRAWING No.		SECTION No.
P-JAL-B-610		700002613
G102433		G102433

TOLERANCE CHART CD = CIRCUMSCRIBING CIRCLE

DIMENSION	CD≤100	100<CD≤200	200<CD≤300	300<CD≤500
UPTO 10mm	±0.40	±0.50	±0.55	±0.60
10.0 - 25.0	±0.50	±0.70	±0.80	±0.90
25.0 - 50.0	±0.80	±0.90	±1.00	±1.20
50.0 - 100	±1.00	±1.20	±1.30	±1.60
100 - 150	-	±1.50	±1.70	±1.80
150 - 200	-	±1.90	±2.20	±2.40
200 - 300	-	-	±2.50	±2.80
300 - 450	-	-	-	±3.50