

P-JAL-B-596

G102463

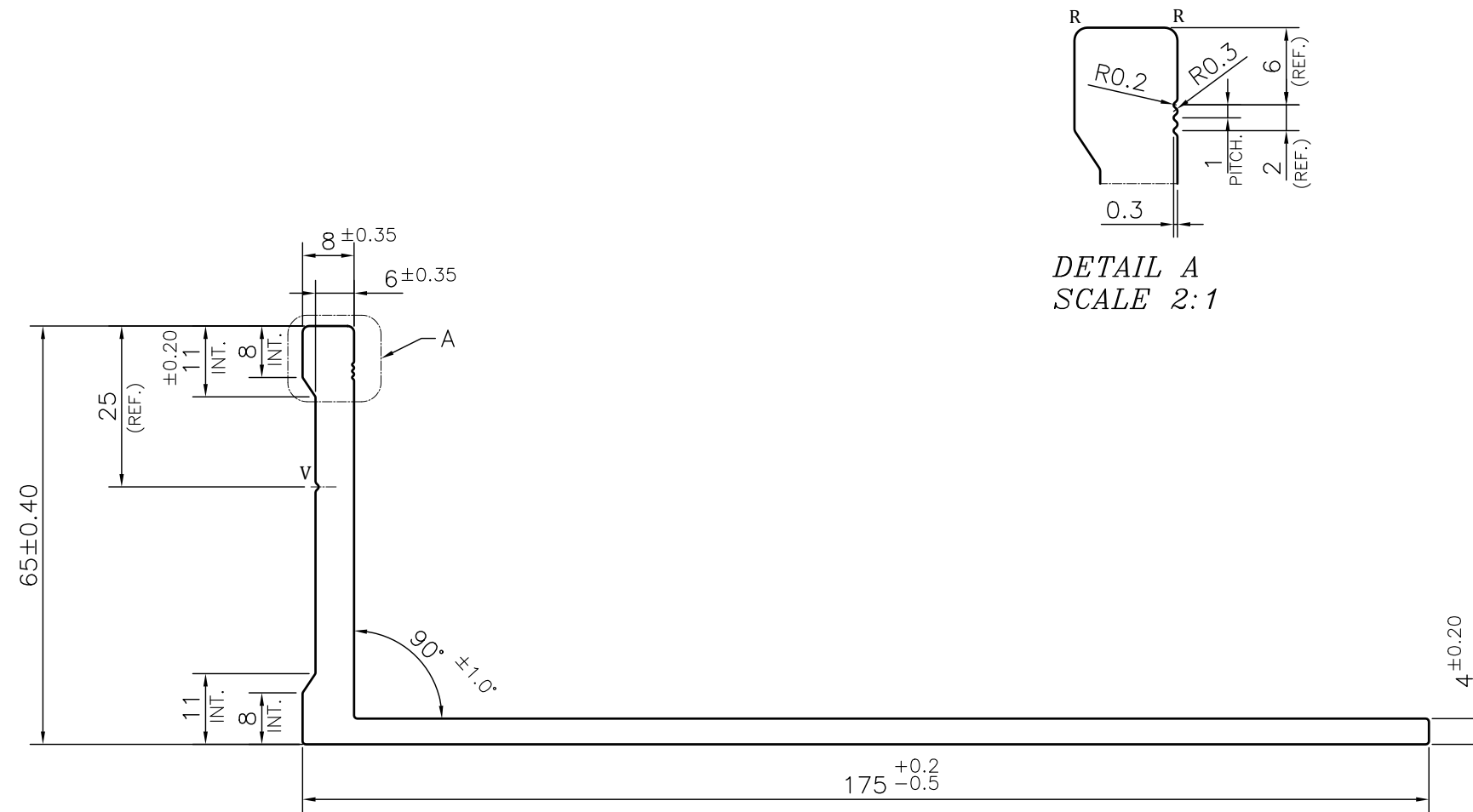

DETAIL A  
SCALE 2:1

NOTE:-

- ☞ ROUND OFF ALL SHARP CORNERS WITH 0.50 mm.
- ☞ ALL EXTRUSION, THAT WILL BE SUPPLIED, SHALL BE WITH TEST CERTIFICATE & PATROL INSPECTION REPORT

**NOTE:-**  
**R= 1.0 RADIUS (2 PLACES)**  
**V= 0.5x90° V-GROOVE (2 PLACES)**

1. STRAIGHTNESS= 1.0mm/M
2. TWIST= 1.0mm/M
3. ANGULARITY= ±1°
4. FLATNESS= ±1.0mm

Q01638

CONTROLLED COPY

 SYMBOL OF QUALITY AN ISO 9001 COMPANY	<b>JINDAL ALUMINIUM LTD.</b> BHIWADI-301019 (INDIA)		NAME	DATE	
			DRAWN	ASHUTOSH	13-06-2024
1. ALL DIMENSIONS ARE IN mm. 2. ROUND OFF ALL SHARP CORNERS WITH 0.40 mm. 3. TOLERANCES WILL BE AS PER BS:EN-755-9,2001, UNLESS OTHERWISE SPECIFIED			CHECKED	PARVESH	04-07-2024
			APPROVED	N.K.HOLEY	04-07-2024
PARTY'S NAME SB SCAFFOLDING INDIA PVT. LTD.			SCALE	1:1	
			AREA mm <sup>2</sup>	1094.625	
PARTY'S DRAWING No. AS PER DRAWING-L SECTION 65_125 TO 300			PERIMETER mm.	480.43	
			WEIGHT kg/m	2.955	
ALLOY & TEMPER 6061 T6			DRAWING No.	SECTION No.	
			P-JAL-B-596	7000002649	
DESCRIPTION FORM WORK SECTION L EXTRUDED SECTION 65X175			G102463	G102463	
			PRODUCT CODE:-029		
			HSN CODE:- 76042990		