

P-JAL-B-597

G102464

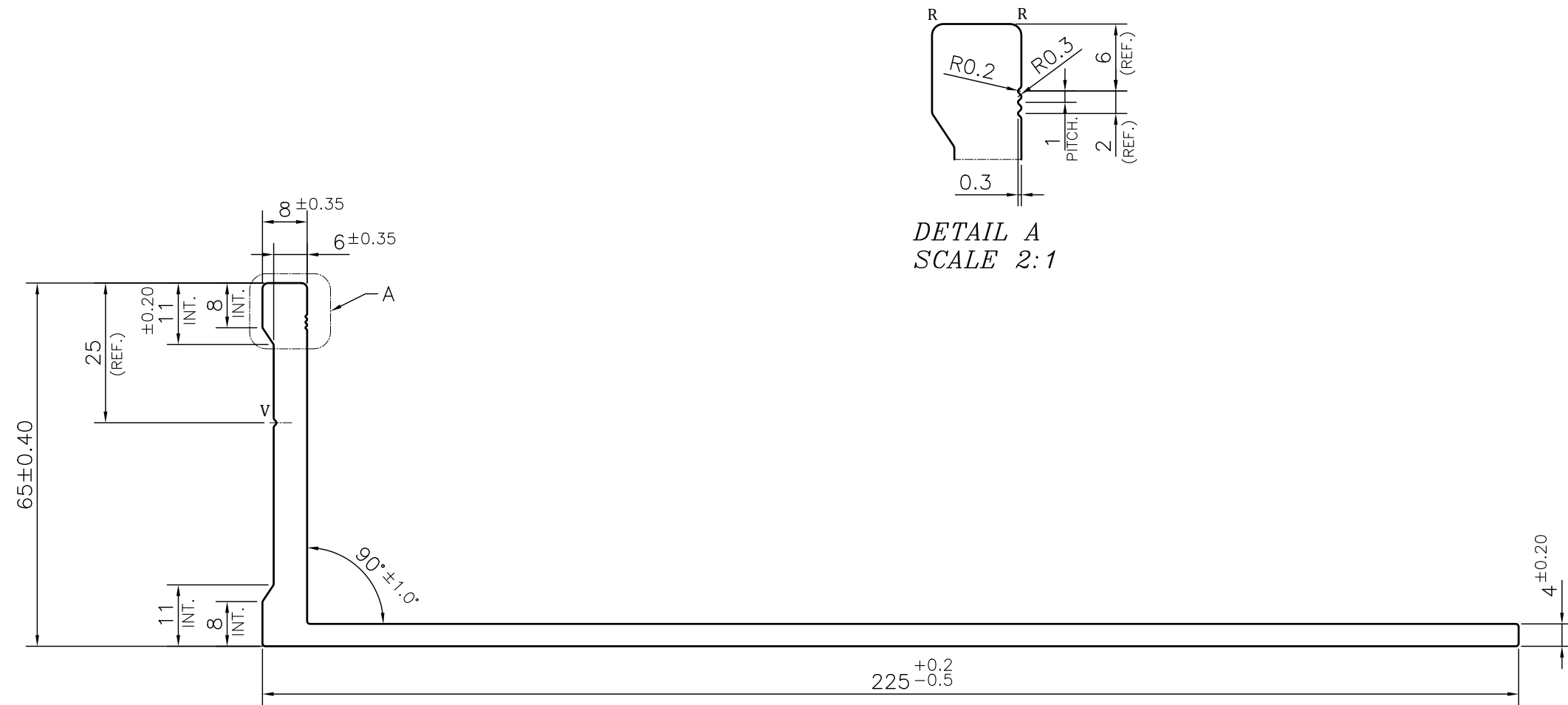

DETAIL A
SCALE 2:1

NOTE:-

- ☞ ROUND OFF ALL SHARP CORNERS WITH 0.50 mm.
- ☞ ALL EXTRUSION, THAT WILL BE SUPPLIED, SHALL BE WITH TEST CERTIFICATE & PATROL INSPECTION REPORT

NOTE:-

- R= 1.0 RADIUS (2 PLACES)**
- V= 0.5x90° V-GROOVE (2 PLACES)**

1. STRAIGHTNESS= 1.0mm/M
2. TWIST= 1.0mm/M
3. ANGULARITY= ±1°
4. FLATNESS= ±1.0mm

Q01640

CONTROLLED COPY

 SYMBOL OF QUALITY AN ISO 9001 COMPANY	JINDAL ALUMINIUM LTD. BHIWADI-301019 (INDIA)		NAME	DATE	
			DRAWN	ASHUTOSH	13-06-2024
1. ALL DIMENSIONS ARE IN mm. 2. ROUND OFF ALL SHARP CORNERS WITH 0.40 mm. 3. TOLERANCES WILL BE AS PER BS:EN-755-9,2001, UNLESS OTHERWISE SPECIFIED			CHECKED	PARVESH	04-07-2024
			APPROVED	N.K.HOLEY	04-07-2024
PARTY'S NAME SB SCAFFOLDING INDIA PVT. LTD.			SCALE	1:1	
			AREA mm ²	1294.625	
PARTY'S DRAWING No. AS PER DRAWING-L SECTION 65_125 TO 300			PERIMETER mm.	580.43	
			WEIGHT kg/m	3.495	
ALLOY & TEMPER 6061 T6			DRAWING No.	SECTION No.	
			P-JAL-B-597	7000002650	
DESCRIPTION FORM WORK SECTION L EXTRUDED SECTION 65X225			G102464	G102464	
			PRODUCT CODE:-029		
			HSN CODE:- 76042990		