

P-JAL-B-651-1

G102596

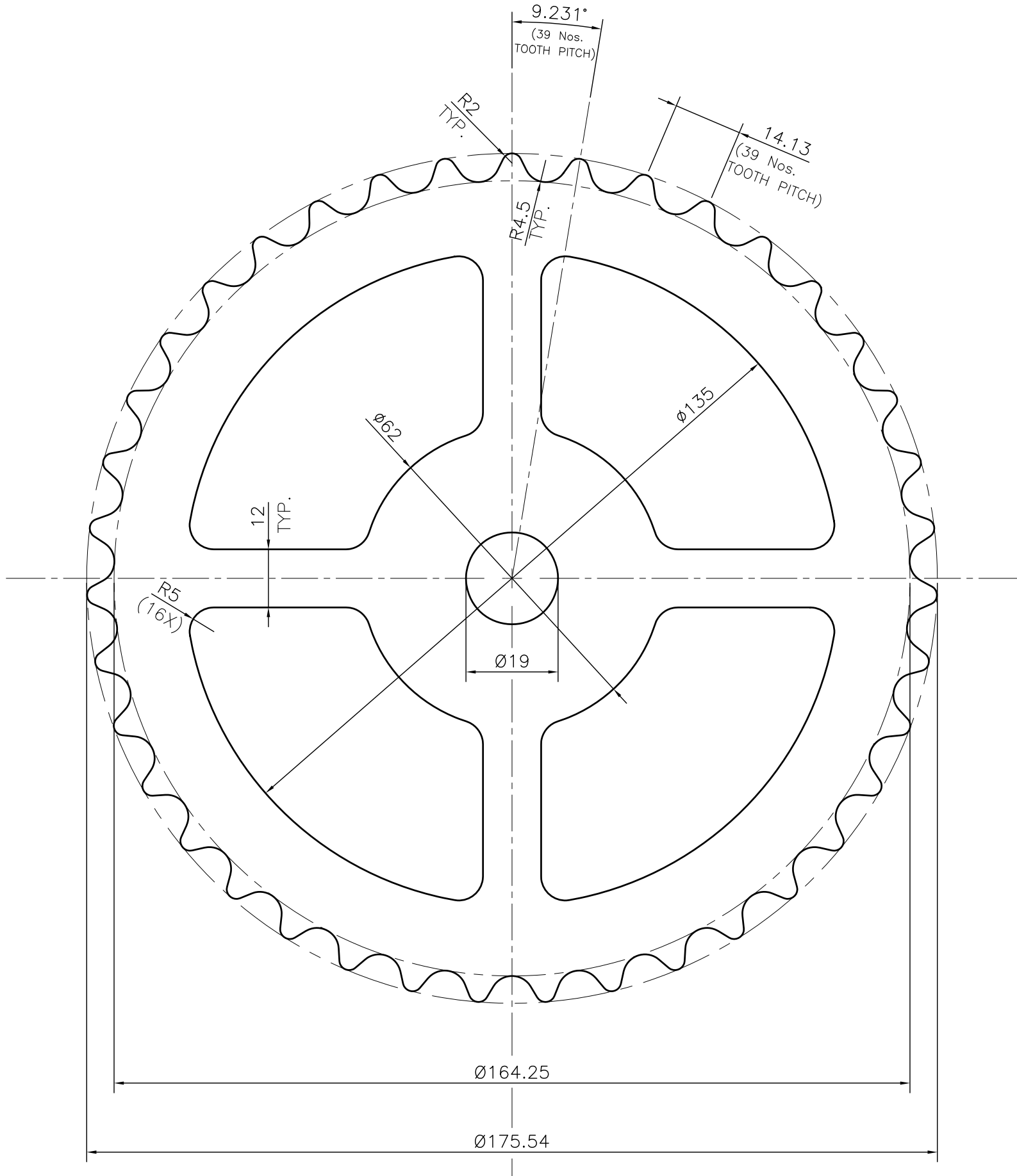

1. STRAIGHTNESS= 1.7mm/M
2. TWIST= 1.7mm/M
3. ANGULARITY= ±2°
4. FLATNESS= 0.007xWIDTH

Q02206

CONTROLLED COPY

| | | | | | |
|---|--|--|----------------------|-------------|------------|
|  SYMBOL OF QUALITY AN ISO 9001 COMPANY | JINDAL ALUMINIUM LTD. BHIWADI-301019 (INDIA) | | NAME | DATE | |
| | | | DRAWN | ASHUTOSH | 16-07-2024 |
| 1. ALL DIMENSIONS ARE IN mm. 2. ROUND OFF ALL SHARP CORNERS WITH 0.40 mm. 3. TOLERANCES WILL BE AS PER BS:EN-755-9 , UNLESS OTHERWISE SPECIFIED | | | CHECKED | PARVESH | 05-08-2024 |
| | | | APPROVED | J.N.RAI | 06-08-2024 |
| | | | SCALE | 1:1 | |
| PARTY'S NAME JINDAL ALUMINIUM LTD., BHIWADI | | | AREA mm ² | 12684.939 | |
| | | | PERIMETER mm. | 736.145 | |
| PARTY'S DRAWING No. AS PER DRAWING-APS-BP5-14/1-A3 | | | WEIGHT kg/m | 34.249 | |
| | | | DRAWING No. | SECTION No. | |
| ALLOY & TEMPER HE30 | | | P-JAL-B-651-1 | 7000002802 | |
| | | | G102596 | G102596 | |
| DESCRIPTION CONVEYOR PULLEY SECTION | | | PRODUCT CODE:-085 | | |
| | | | HSN CODE:- 76042100 | | |