

P-JAL-B-669

G102610

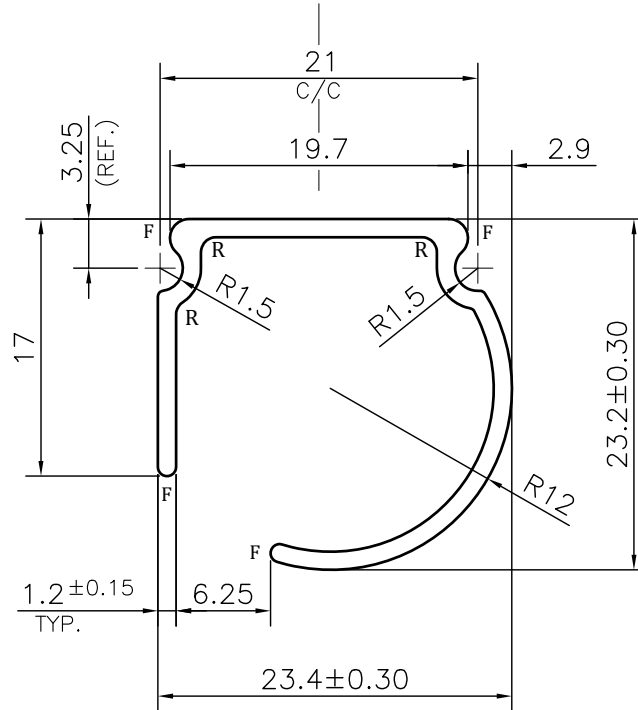

SCALE 1:1



**NOTE:-**

**R= 1.0 RADIUS (3 PLACES)**  
**F= FULL RADIUS (4 PLACES)**

TOLERANCE CHART CD = CIRCUMSCRIBING CIRCLE

DIMENSION	CD<100	100<CD<200	200<CD<300	300<CD<500
UPTO 10mm	±0.25	±0.30	±0.35	±0.40
10.0 -25.0	±0.30	±0.40	±0.50	±0.60
25.0 -50.0	±0.50	±0.60	±0.80	±0.90
50.0 -100	±0.70	±0.90	±1.10	±1.30
100 - 150	-	±1.10	±1.30	±1.50
150 - 200	-	±1.3	±1.50	±1.80
200 - 300	-	-	±1.70	±2.10
300 - 450	-	-	-	±2.80

Q02170

CONTROLLED COPY

1. STRAIGHTNESS= 1.7mm/M
2. TWIST= 1.7mm/M
3. ANGULARITY= ±2°
4. FLATNESS= 0.007xWIDTH



SYMBOL OF QUALITY  
AN ISO 9001 COMPANY

**JINDAL ALUMINIUM LTD.**  
 BHIWADI-301019 (INDIA)

	NAME	DATE
DRAWN	ASHUTOSH	29-07-2024
CHECKED	PARVESH	09-08-2024
APPROVED	J.N.RAI	09-08-2024

1. ALL DIMENSIONS ARE IN mm.
2. ROUND OFF ALL SHARP CORNERS WITH 0.40 mm.
3. TOLERANCES WILL BE AS PER BS:EN-755-9 , UNLESS OTHERWISE SPECIFIED

SCALE	2:1
AREA mm <sup>2</sup>	81.771
PERIMETER mm.	137.82
WEIGHT kg/m	0.221

PARTY'S NAME	ATCO ALUMINIUM SYSTEM, DELHI	
PARTY'S DRAWING No.	AS PER PROPOSAL DRAWING	
ALLOY & TEMPER	6063 T6	PRODUCT CODE:-049
		HSN CODE:- 76042990
DESCRIPTION	VENETIAN BLIND SECTION	

DRAWING No.	SECTION No.
P-JAL-B-669	7000002821
G102610	G102610