

P-JAL-B-671

G102676

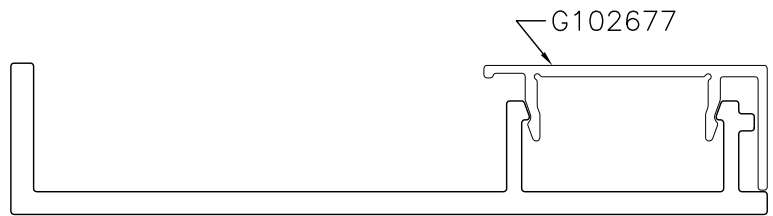

**MATCHING
SCALE 1:1**

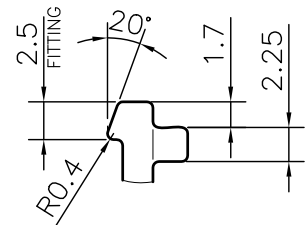
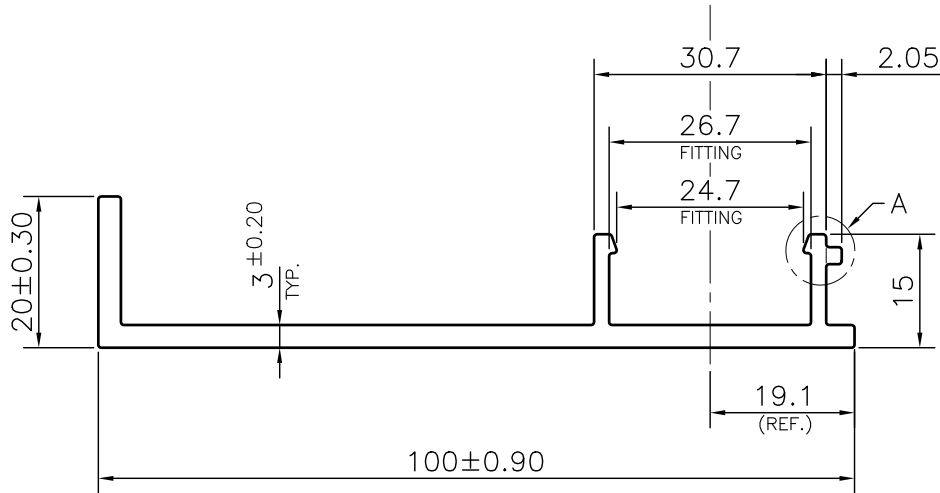

**DETAIL A
SCALE 2:1**

TOLERANCE CHART CD = CIRCUMSCRIBING CIRCLE

DIMENSION	CD<100	100<CD<200	200<CD<300	300<CD<500
UPTO 10mm	±0.25	±0.30	±0.35	±0.40
10.0 -25.0	±0.30	±0.40	±0.50	±0.60
25.0 -50.0	±0.50	±0.60	±0.80	±0.90
50.0 -100	±0.70	±0.90	±1.10	±1.30
100 - 150	-	±1.10	±1.30	±1.50
150 - 200	-	±1.3	±1.50	±1.80
200 - 300	-	-	±1.70	±2.10
300 - 450	-	-	-	±2.80

Q02065

CONTROLLED COPY

1. STRAIGHTNESS= 1.7mm/M
2. TWIST= 1.7mm/M
3. ANGULARITY= ±2°
4. FLATNESS= 0.007xWIDTH



SYMBOL OF QUALITY
AN ISO 9001 COMPANY

JINDAL ALUMINIUM LTD.
BHIWADI-301019 (INDIA)

	NAME	DATE
DRAWN	ASHUTOSH	02-08-2024
CHECKED	PARVESH	23-08-2024
APPROVED	J.N.RAI	23-08-2024

1. ALL DIMENSIONS ARE IN mm.
2. ROUND OFF ALL SHARP CORNERS WITH 0.40 mm.
3. TOLERANCES WILL BE AS PER BS:EN-755-9 , UNLESS OTHERWISE SPECIFIED

SCALE	1:1
AREA mm ²	407.016
PERIMETER mm.	291.3
WEIGHT kg/m	1.099
DRAWING No.	SECTION No.
P-JAL-B-671	7000002876
G102676	G102676

PARTY'S NAME	K.S.V. INFRABUILD GREATER NOIDA	
PARTY'S DRAWING No.	AS PER DRAWING -KSV -BR-S03	
ALLOY & TEMPER	6063 T6	PRODUCT CODE:-055
		HSN CODE:- 76042990
DESCRIPTION	CURTAIN WALL SECTION- GLASS FRAME	