

P-JAL-B-718

G102730

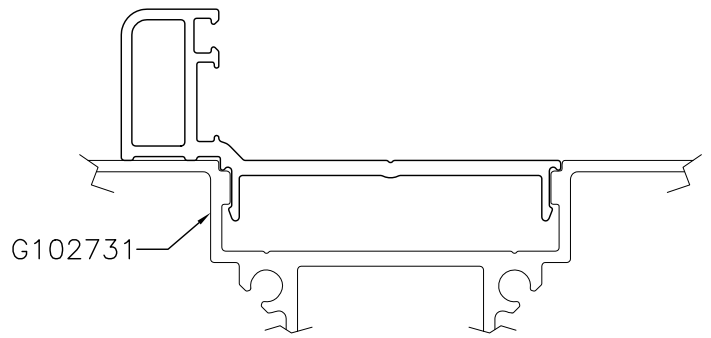

MATCHING
SCALE 1:1

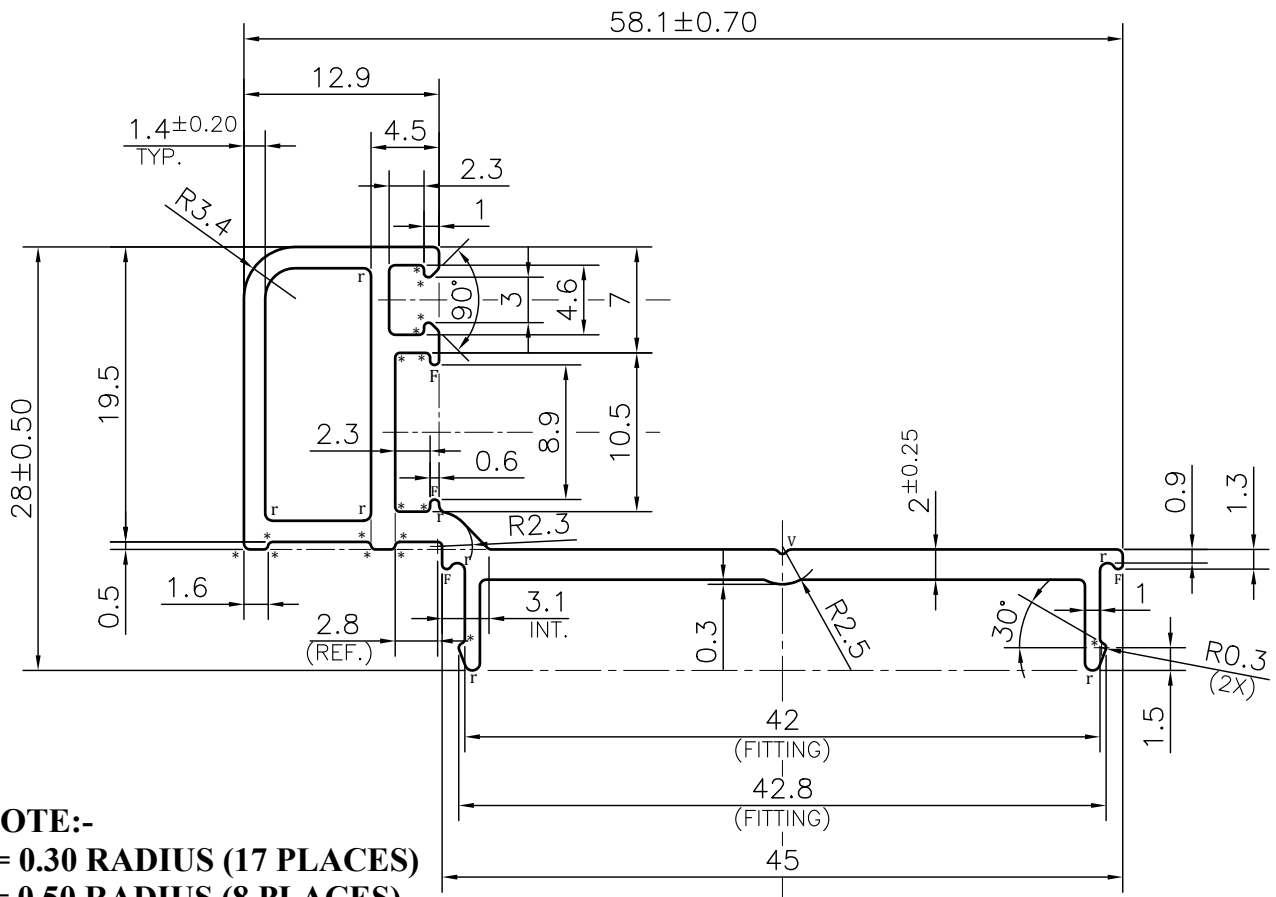

NOTE:-

- *= 0.30 RADIUS (17 PLACES)
- r= 0.50 RADIUS (8 PLACES)
- F= FULL RADIUS (4 PLACES)
- V= 0.3x90°V-GROOVE (1 PLACE)

- 1. STRAIGHTNESS= 1.7mm/M
- 2. TWIST= 1.7mm/M
- 3. ANGULARITY= ±2°
- 4. FLATNESS= 0.007xWIDTH

Q02248

CONTROLLED COPY



SYMBOL OF QUALITY
AN ISO 9001 COMPANY

JINDAL ALUMINIUM LTD.
BHIWADI-301019 (INDIA)

	NAME	DATE
DRAWN	ASHUTOSH	02-09-2024
CHECKED	PARVESH	05-09-2024
APPROVED	J.N.RAI	05-09-2024
SCALE		2:1
AREA mm ²		196.511
PERIMETER mm.		197.765
WEIGHT kg/m		0.531
DRAWING No.	SECTION No.	
P-JAL-B-718	7000002936	
G102730	G102730	

- 1. ALL DIMENSIONS ARE IN mm.
- 2. ROUND OFF ALL SHARP CORNERS WITH 0.40 mm.
- 3. TOLERANCES WILL BE AS PER BS:EN-755-9 , UNLESS OTHERWISE SPECIFIED

PARTY'S NAME	BNP INTERIORS	
PARTY'S DRAWING No.	AS PER DRAWING P-27634	
ALLOY & TEMPER	6063 T6	PRODUCT CODE:-048
		HSN CODE:- 76042100
DESCRIPTION	WINDOW SECTIONS	