

P-JAL-B-719

G102731

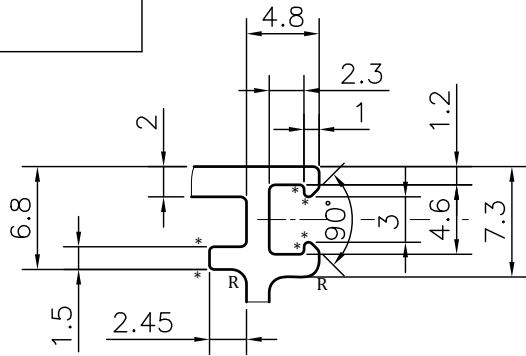

DETAIL A  
SCALE 2:1

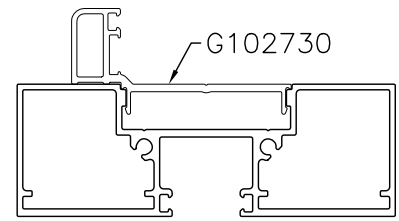

MATCHING

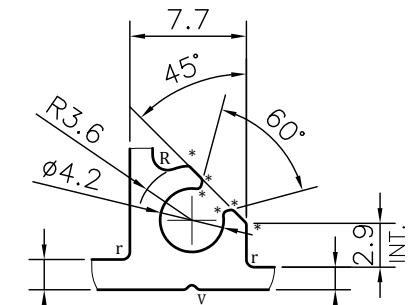

DETAIL B  
SCALE 2:1

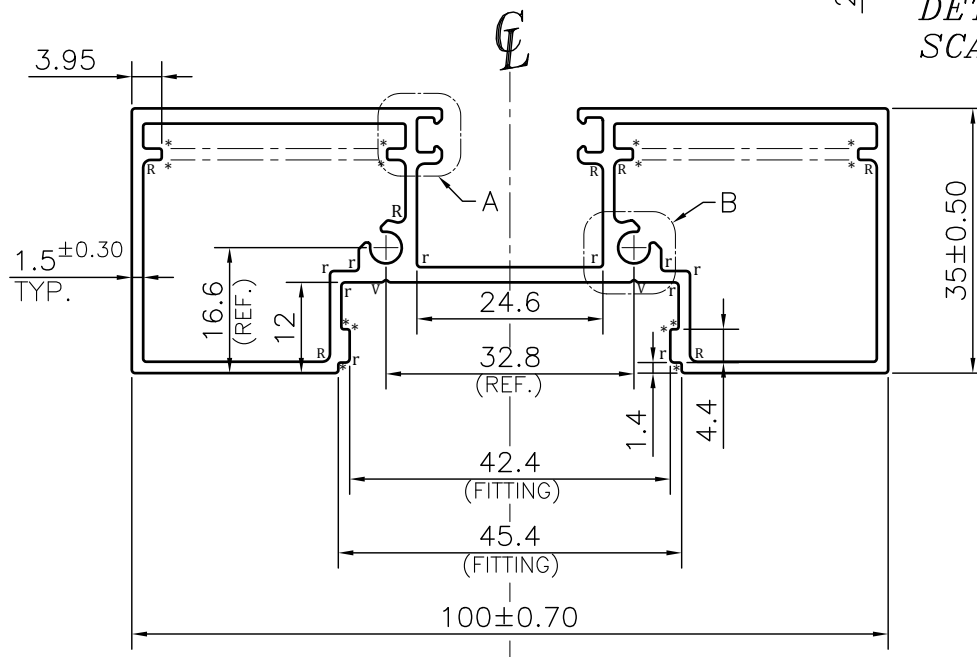

**NOTE:-**

- \*= 0.30 RADIUS (38 PLACES)
- r= 0.50 RADIUS (10 PLACES)
- R= 1.0 RADIUS (10 PLACES)
- V= 0.3x90°V-GROOVE (2 PLACES)

- 1. STRAIGHTNESS= 1.7mm/M
- 2. TWIST= 1.7mm/M
- 3. ANGULARITY= ±2°
- 4. FLATNESS= 0.007xWIDTH

Q02249

CONTROLLED COPY



SYMBOL OF QUALITY  
AN ISO 9001 COMPANY

**JINDAL ALUMINIUM LTD.**  
BHIWADI-301019 (INDIA)

- 1. ALL DIMENSIONS ARE IN mm.
- 2. ROUND OFF ALL SHARP CORNERS WITH 0.40 mm.
- 3. TOLERANCES WILL BE AS PER BS:EN-755-9 , UNLESS OTHERWISE SPECIFIED

PARTY'S NAME	BNP INTERIORS	SCALE	1:1
PARTY'S DRAWING No.	AS PER DRAWING P-27635	AREA mm <sup>2</sup>	585.114
ALLOY & TEMPER	6063 T6	PERIMETER mm.	365.24
DESCRIPTION	WINDOW SECTIONS	WEIGHT kg/m	1.58
		DRAWING No.	SECTION No.
		P-JAL-B-719	7000002937
		G102731	G102731