

P-JAL-B-918

G103624

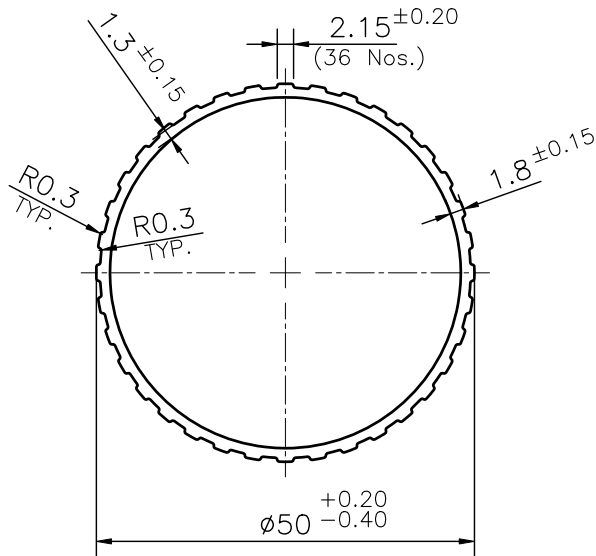

1. STRAIGHTNESS= 1.7mm/M
2. TWIST= 1.7mm/M
3. ANGULARITY= $\pm 2^\circ$
4. FLATNESS= 0.007xWIDTH

Q02571Q02572

CONTROLLED COPY



SYMBOL OF QUALITY
AN ISO 9001 COMPANY

JINDAL ALUMINIUM LTD.
BHIWADI-301019 (INDIA)

	NAME	DATE
DRAWN	ASHUTOSH	28-01-2025
CHECKED	PARVESH	03-03-2025
APPROVED	J.N.RAI	03-03-2025

1. ALL DIMENSIONS ARE IN mm.
2. ROUND OFF ALL SHARP CORNERS WITH 0.30 mm.
3. TOLERANCES WILL BE AS PER BS:EN-755-9 , UNLESS OTHERWISE SPECIFIED

SCALE	1:1
AREA mm ²	233.392
PERIMETER mm.	173.526
WEIGHT kg/m	0.630

PARTY'S NAME	MSAFE EQUIPMENTS PVT LTD., NOIDA		DRAWING No.	SECTION No.
PARTY'S DRAWING No.	AS PER PROPOSAL DRAWING		P-JAL-B-918	7000003863
ALLOY & TEMPER	6063 T6/6005 T6	PRODUCT CODE:-011	G103624	G103624
		HSN CODE:- 76042100		
DESCRIPTION	FLUTED ROUND TUBE			