

P-JAL-B-924-1

G103736

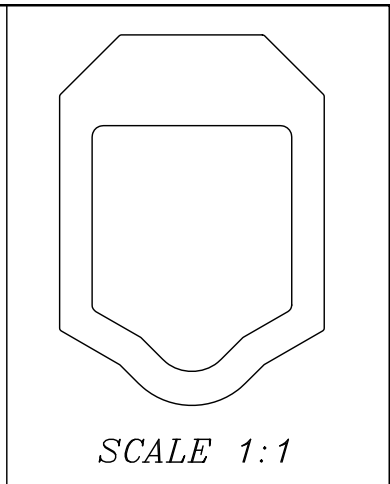
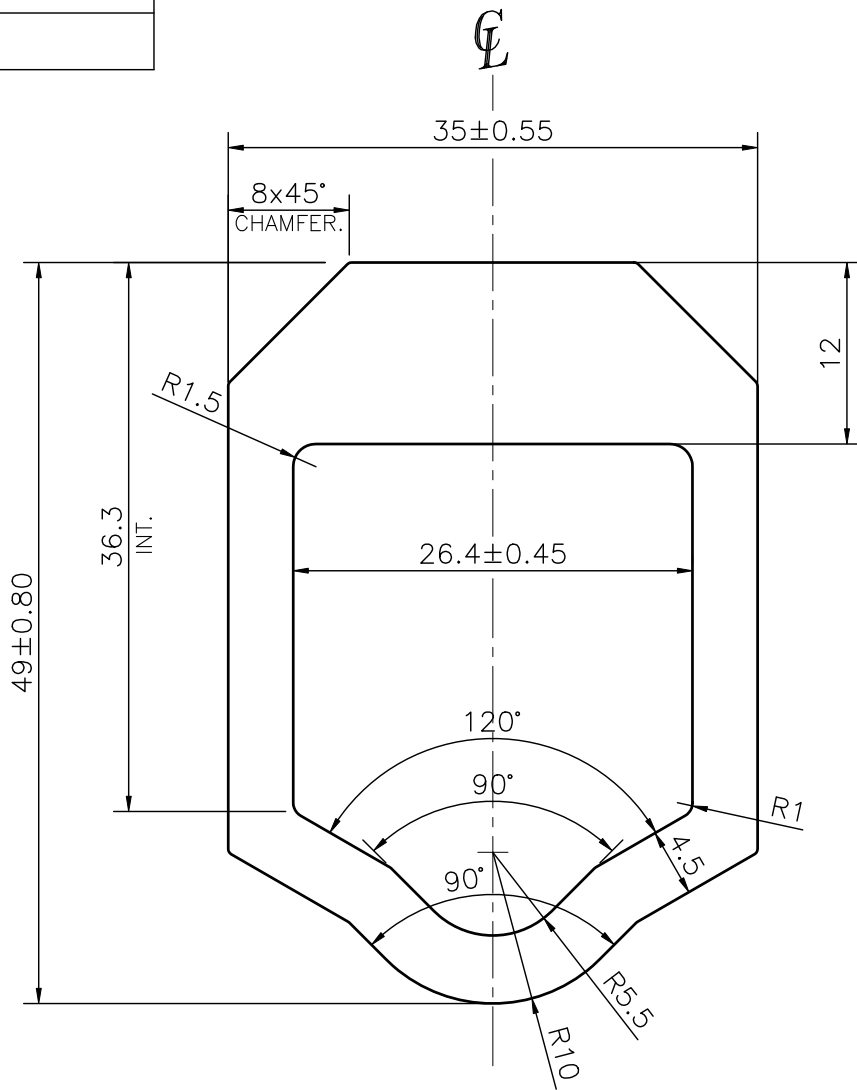

TOLERANCE CHART CD = CIRCUMSCRIBING CIRCLE

DIMENSION	CD<100	100<CD<200	200<CD<300	300<CD<500
UPTO 10mm	±0.40	±0.50	±0.55	±0.60
10.0 -25.0	±0.50	±0.70	±0.80	±0.90
25.0 -50.0	±0.80	±0.90	±1.00	±1.20
50.0 -100	±1.00	±1.20	±1.30	±1.60
100 - 150	-	±1.50	±1.70	±1.80
150 - 200	-	±1.90	±2.20	±2.40
200 - 300	-	-	±2.50	±2.80
300 - 450	-	-	-	±3.50

Q02727
CONTROLLED COPY

FINISH - MILL FINISH

1. STRAIGHTNESS= 1.7mm/M
2. TWIST= 1.7mm/M
3. ANGULARITY= ±2°
4. FLATNESS= 0.007xWIDTH



SYMBOL OF QUALITY
AN ISO 9001 COMPANY

JINDAL ALUMINIUM LTD.
BHIWADI-301019 (INDIA)

	NAME	DATE
DRAWN	ASHUTOSH	04-02-2025
CHECKED	PARVESH	04-04-2025
APPROVED	J.N.RAI	04-04-2025

1. ALL DIMENSIONS ARE IN mm.
2. ROUND OFF ALL SHARP CORNERS WITH 0.40 mm.
3. TOLERANCES WILL BE AS PER BS:EN-755-9 , UNLESS OTHERWISE SPECIFIED

SCALE	2:1
AREA mm ²	741.26
PERIMETER mm.	144.564
WEIGHT kg/m	2.001
DRAWING No.	SECTION No.
P-JAL-B-924-1	7000004012
G103736	G103736

PARTY'S NAME	R PLUS V IMPEX, LUDHIANA	
PARTY'S DRAWING No.	AS PER CAD DRAWING	
ALLOY & TEMPER	EN AW-6082 T6	PRODUCT CODE:-085
		HSN CODE:- 76042100
DESCRIPTION	INDUSTRIAL SECTION	