

P-JAL-B-984-1

G103763

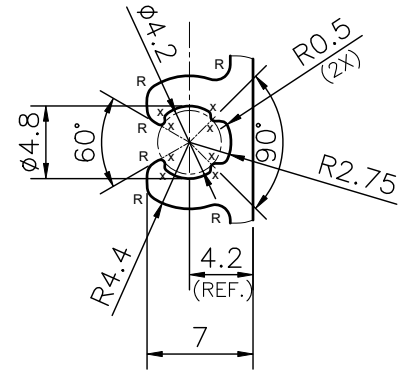

DETAIL A
SCALE 2:1

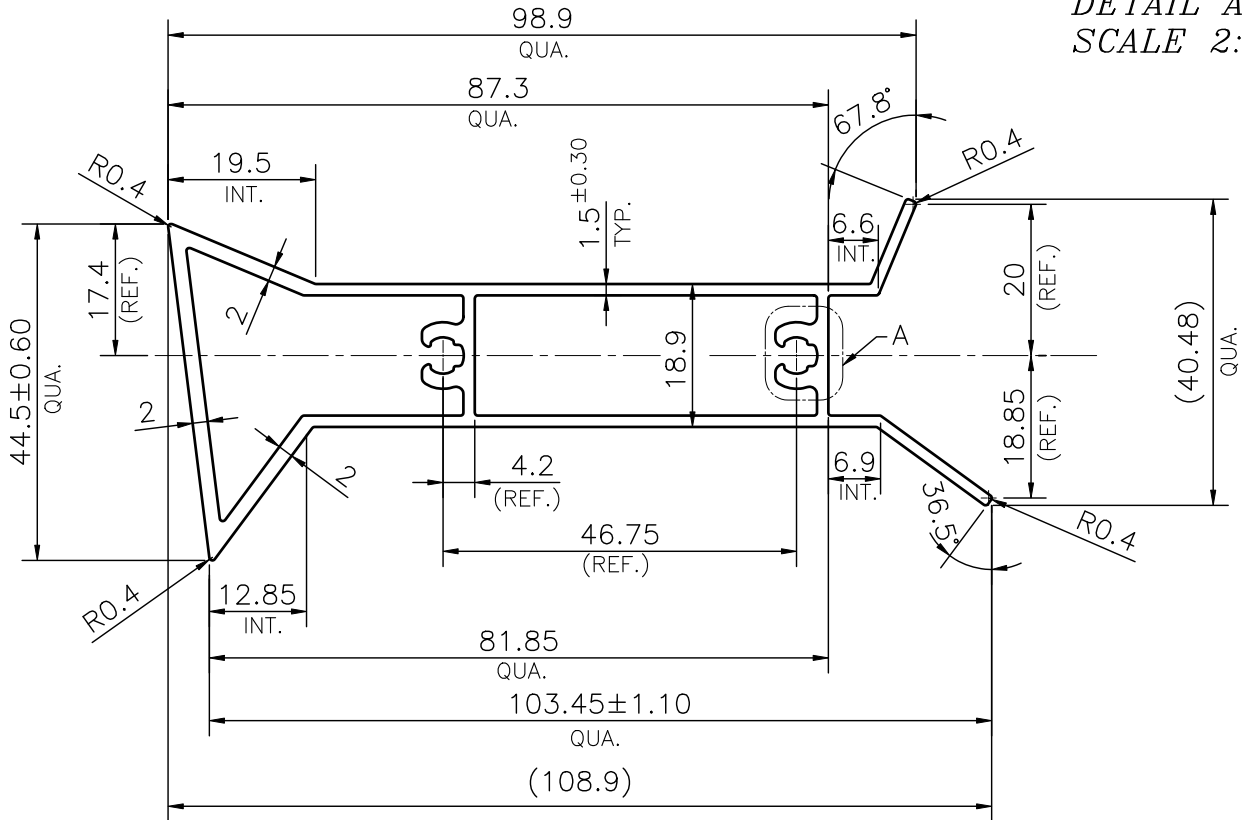

NOTE:-

- x= 0.30 RADIUS (16 PLACES)
- R= 1.0 RADIUS (12 PLACES)

1. STRAIGHTNESS= 1.7mm/M
2. TWIST= 1.7mm/M
3. ANGULARITY= ±2°
4. FLATNESS= 0.007xWIDTH

Q03206

CONTROLLED COPY



SYMBOL OF QUALITY
AN ISO 9001 COMPANY

JINDAL ALUMINIUM LTD.
BHIWADI-301019 (INDIA)

	NAME	DATE
DRAWN	ASHUTOSH	12-03-2025
CHECKED	PARVESH	11-04-2025
APPROVED	J.N.RAI	11-04-2025

1. ALL DIMENSIONS ARE IN mm.
2. ROUND OFF ALL SHARP CORNERS WITH 0.40 mm.
3. TOLERANCES WILL BE AS PER BS:EN-755-9 , UNLESS OTHERWISE SPECIFIED

SCALE	1:1
AREA mm ²	533.435
PERIMETER mm.	329.135
WEIGHT kg/m	1.44

PARTY'S NAME	AXSYS SOLUTION, HIMACHAL PRADESH	
PARTY'S DRAWING No.	AS PER CAD DRAWING (90° CORNER BULLET PROOF GLASS PROFILE)	
ALLOY & TEMPER	6063 T6	PRODUCT CODE:-055
		HSN CODE:- 76042100
DESCRIPTION	CURTAIN WALL SECTION	

DRAWING No.	SECTION No.
P-JAL-B-984-1	7000004050
G103763	G103763