

P-13182-1

S3923

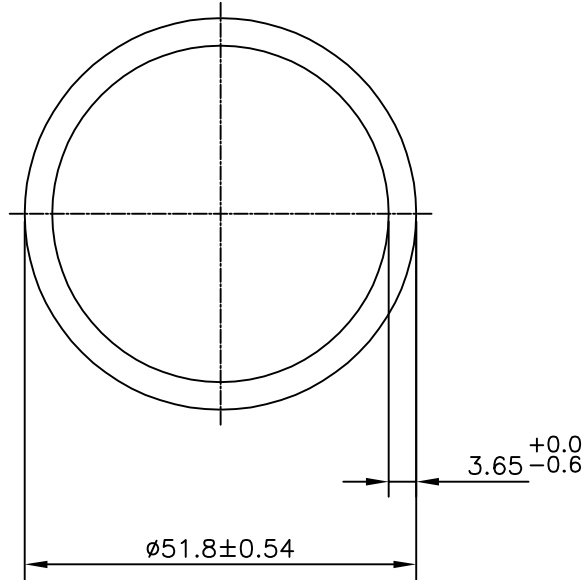

1. OVALITLY = ± 1 mm.



SYMBOL OF QUALITY
AN ISO 9001 COMPANY

JINDAL ALUMINIUM LTD.
BANGALORE-560073 (INDIA)

	NAME	DATE
DRAWN	PARVESH	16-11-2013
CHECKED		
APPROVED	S.S.GARG	20-11-2013
SCALE		1:1
AREA mm ²		552.127
PERIMETER mm.		162.734
WEIGHT kg/m		1.491
DRAWING No.	SECTION No.	
P-13182-1	-	
S3923	S3923	

1. ALL DIMENSIONS ARE IN mm.
2. ROUND OFF ALL SHARP CORNERS WITH 0.40 mm.
3. TOLERANCES WILL BE AS PER IS:2673-2002 , UNLESS OTHERWISE SPECIFIED

PARTY'S NAME	BRUSH TECH INDIA, MYSORE
PARTY'S DRAWING No.	AS PER SPECIFICATION
ALLOY & TEMPER	6063 T6
DESCRIPTION	ROUND TUBE