

P-13882

S4210

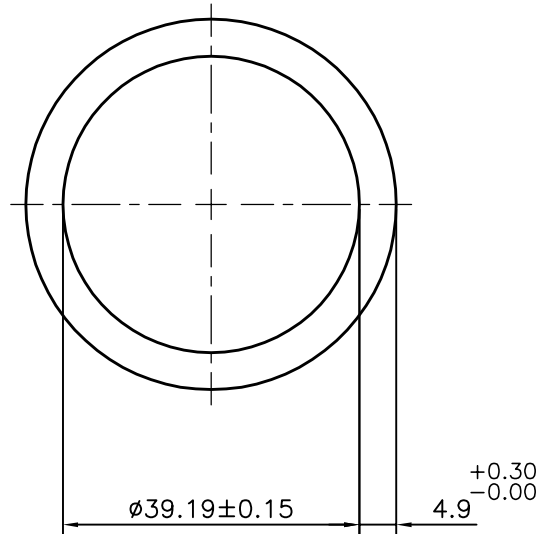

ISSUE-2

TOLERANCE CHANGED ON THICKNESS 4.9 ± 0.15 TO 4.9 $+0.30$ -0.00



SYMBOL OF QUALITY
AN ISO 9001 COMPANY

JINDAL ALUMINIUM LTD.
BANGALORE-560073 (INDIA)

	NAME	DATE
DRAWN	J.P.KAUSHIK	13-11-2014
CHECKED		
APPROVED	S.S.GARG	14-11-2014
SCALE		1:1
AREA mm ²		678.713
PERIMETER mm.		153.907
WEIGHT kg/m		1.833
DRAWING No.		SECTION No.
P-13882		-
S4210		S4210(ISSUE-2)

1. ALL DIMENSIONS ARE IN mm.
2. ROUND OFF ALL SHARP CORNERS WITH 0.40 mm.
3. TOLERANCES WILL BE AS PER IS:2673-2002, UNLESS OTHERWISE SPECIFIED

PARTY'S NAME	PAHARPUR COOLING TOWERS LTD., KOLKATA
PARTY'S DRAWING No.	AS PER SPECIFICATION
ALLOY & TEMPER	1060 F
DESCRIPTION	ROUND TUBE