

P-14087-1

S4295

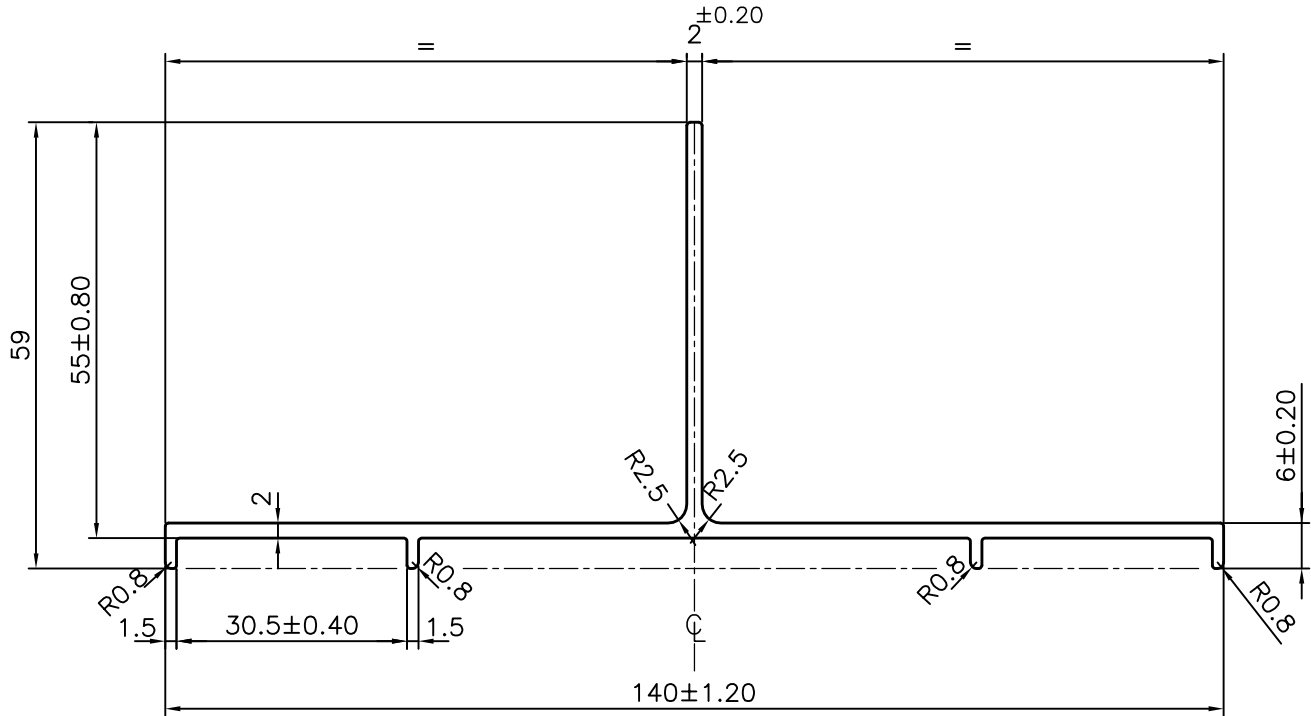

SYMBOL OF QUALITY
AN ISO 9001 COMPANY

JINDAL ALUMINIUM LTD.
BANGALORE-560073 (INDIA)

	NAME	DATE
DRAWN	J.P.KAUSHIK	11-11-2014
CHECKED		
APPROVED	S.S.GARG	13-11-2014
SCALE		1:1
AREA mm ²		412.064
PERIMETER mm.		416.077
WEIGHT kg/m		1.113
DRAWING No.	SECTION No.	
P-14087-1	-	
S4295	S4295	

1. ALL DIMENSIONS ARE IN mm.
2. ROUND OFF ALL SHARP CORNERS WITH 0.40 mm.
3. TOLERANCES WILL BE AS PER IS:3965-1981, UNLESS OTHERWISE SPECIFIED

PARTY'S NAME	LIGHT METALS, BANGALORE
PARTY'S DRAWING No.	T 002 M1
ALLOY & TEMPER	6063 T66
DESCRIPTION	TEE SECTION-MISC.