

P-14308

S4366

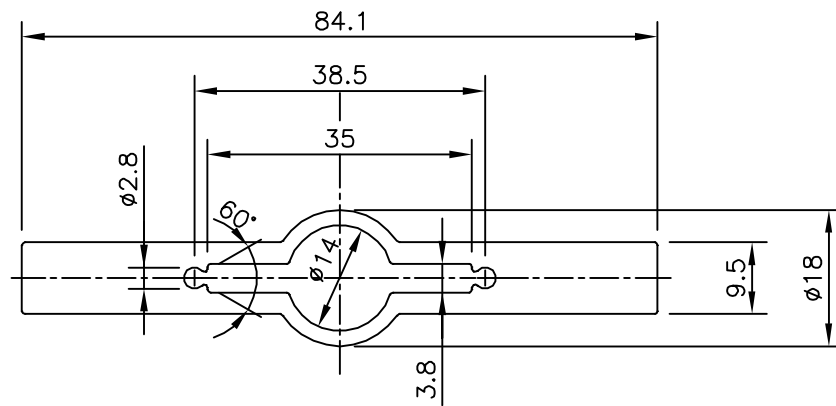
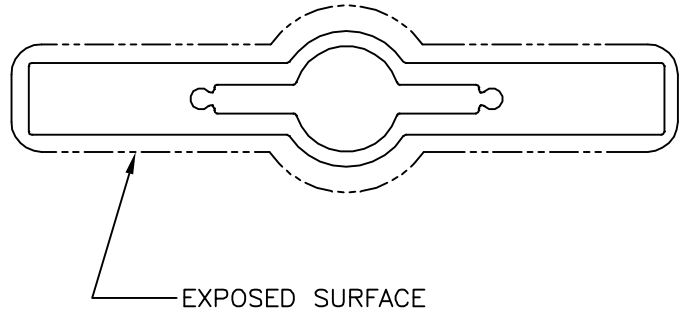

SYMBOL OF QUALITY
AN ISO 9001 COMPANY

JINDAL ALUMINIUM LTD.
BANGALORE-560073 (INDIA)

	NAME	DATE
DRAWN	J.P.KAUSHIK	05-01-2015
CHECKED		
APPROVED	S.S.GARG	23-01-2015
SCALE		1:1
AREA mm ²		642.366
PERIMETER mm.		192.319
WEIGHT kg/m		1.734
DRAWING No.	SECTION No.	
P-14308	-	
S4366	S4366	

1. ALL DIMENSIONS ARE IN mm.
2. ROUND OFF ALL SHARP CORNERS WITH 0.40 mm.
3. TOLERANCES WILL BE AS PER IS:6477-1983, UNLESS OTHERWISE SPECIFIED

PARTY'S NAME	ASSOCIATED LIGHTING COMPANY, NOIDA
PARTY'S DRAWING No.	AS PER DRAWING (TOP PART)
ALLOY & TEMPER	6063 T6
DESCRIPTION	ELECTRICAL SECTION