

P-14417

S4385

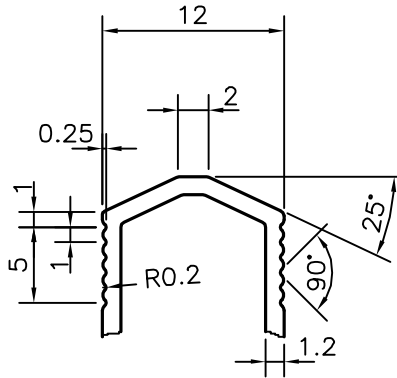

DETAIL OF "A"  
SCALE 2:1

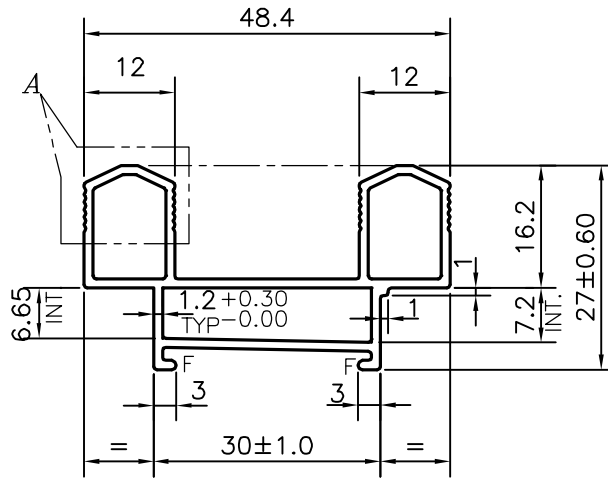

F = FULL RADIUS(2 PLACES)



SYMBOL OF QUALITY  
AN ISO 9001 COMPANY

**JINDAL ALUMINIUM LTD.**  
BANGALORE-560073 (INDIA)

	NAME	DATE
DRAWN	J.P.KAUSHIK	09-02-2015
CHECKED		
APPROVED	S.S.GARG	11-02-2015
SCALE		1:1
AREA mm <sup>2</sup>		206.969
PERIMETER mm.		186.324
WEIGHT kg/m		0.559
DRAWING No.	SECTION No.	
P-14417	-	
S4385	S4385	

1. ALL DIMENSIONS ARE IN mm.
2. ROUND OFF ALL SHARP CORNERS WITH 0.40 mm.
3. TOLERANCES WILL BE AS PER IS:6477-1983 , UNLESS OTHERWISE SPECIFIED

PARTY'S NAME	PARAMOUNT INDUSTRIES, BANGALORE
PARTY'S DRAWING No.	P-AL172416LWA
ALLOY & TEMPER	HE9 WP
DESCRIPTION	WINDOW SECTION