

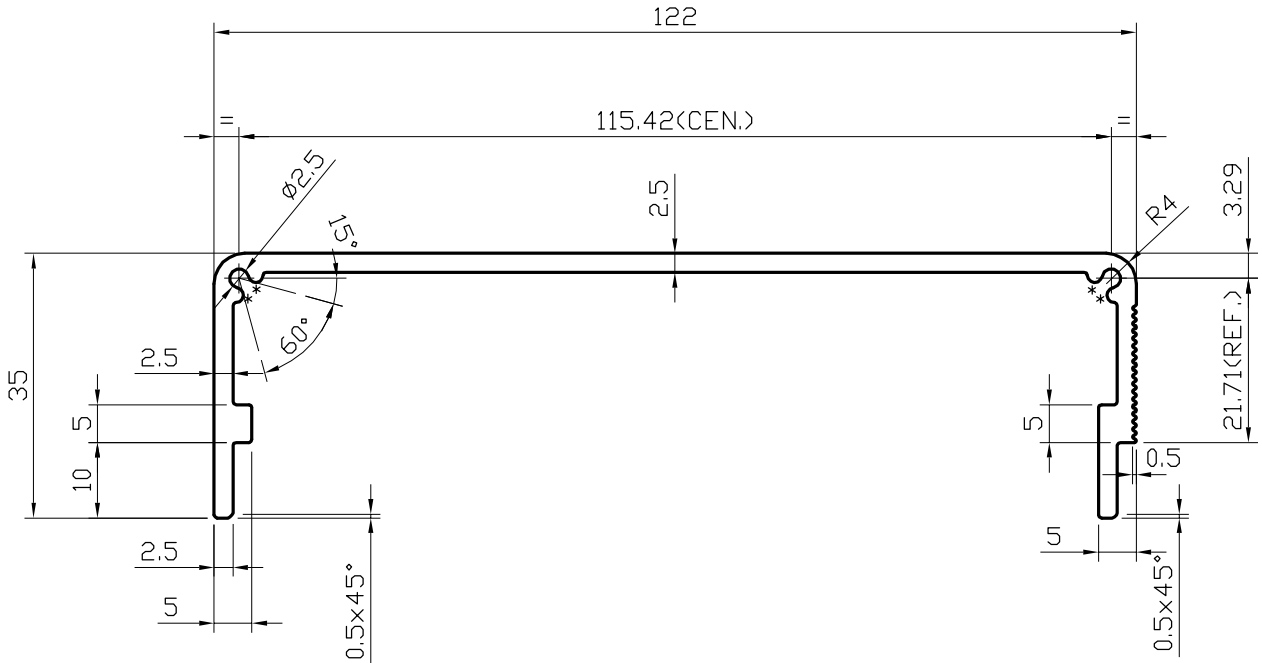

P-14634
S4463
-

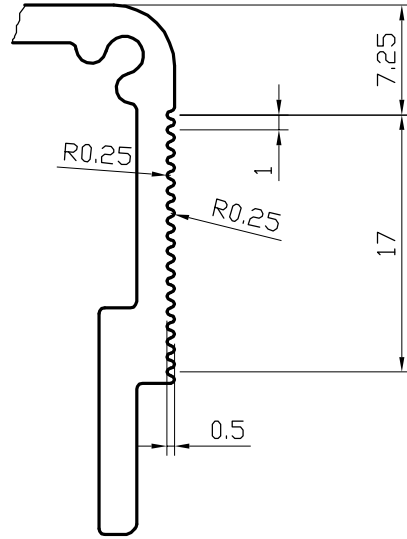
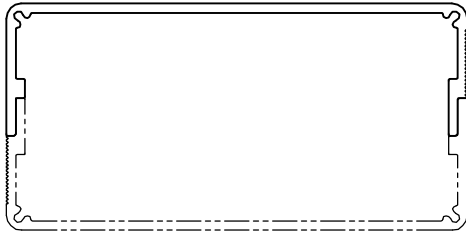

*= 1.0 RADIUS (4 PLASES)

 SYMBOL OF QUALITY AN ISO 9002 COMPANY	JINDAL ALUMINIUM LTD. BANGALORE-560073 (INDIA)	NAME	DATE
		DRAWN	J.P.KAUSHIK
1. ALL DIMENSIONS ARE IN mm. 2. ROUND OFF ALL SHARP CORNERS WITH 0.40 mm. 3. TOLERANCES WILL BE AS PER IS:3965-1981 UNLESS OTHERWISE SPECIFIED		CHECKED	
		APPROVED	S.S.GARG
PARTY'S NAME GALLANT ELECTRONIC CONTROLS,BANGALORE		SCALE	1:1
		AREA mm ²	487.742
PARTY'S DRAWING No. MODIFICATION OF SECTION No:-33521		PERIMETER mm.	400.81
		WEIGHT kg/m	1.317
ALLOY & TEMPER 6063 T6		DRAWING No.	SECTION No.
		P-14634	-
DESCRIPTION HEAT SINK		S4463	S4463
		-	-