

P-14668-1

S4480

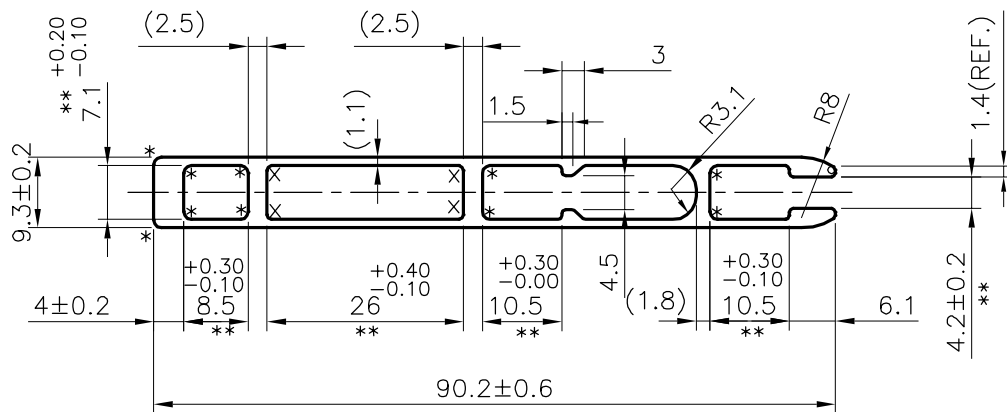

** = IMPORTANT DIMENSIONS

FLATNESS = ± 0.76 mm ON 90.2 mm WIDTH

UNSPECIFIED RADIUS 0.5 mm

x = 0.60 RADIUS (4 PLACES)
 * = 1.0 RADIUS (10 PLACES)



SYMBOL OF QUALITY
 AN ISO 9002 COMPANY

JINDAL ALUMINIUM LTD.
 BANGALORE-560073 (INDIA)

	NAME	DATE
DRAWN	J.P.KAUSHIK	30-05-2015
CHECKED		
APPROVED	S.S.GARG	01-06-2015

1. ALL DIMENSIONS ARE IN mm.
2. ROUND OFF ALL SHARP CORNERS WITH 0.40 mm.
3. TOLERANCES WILL BE AS PER IS:6477-1983 UNLESS OTHERWISE SPECIFIED

SCALE	1:1
AREA mm^2	300.275
PERIMETER mm.	232.701
WEIGHT kg/m	0.811

PARTY'S NAME	BHARAT HEALD FRAME WORKS, BHIWANDI
PARTY'S DRAWING No.	MODIFIED OF SECTION No:-27665 & REQUIREMENT
ALLOY & TEMPER	HE9 WP
DESCRIPTION	TEXTILE SECTION

DRAWING No.	SECTION No.
P-14668-1	-
S4480	S4480