

P-14770-1

S4520

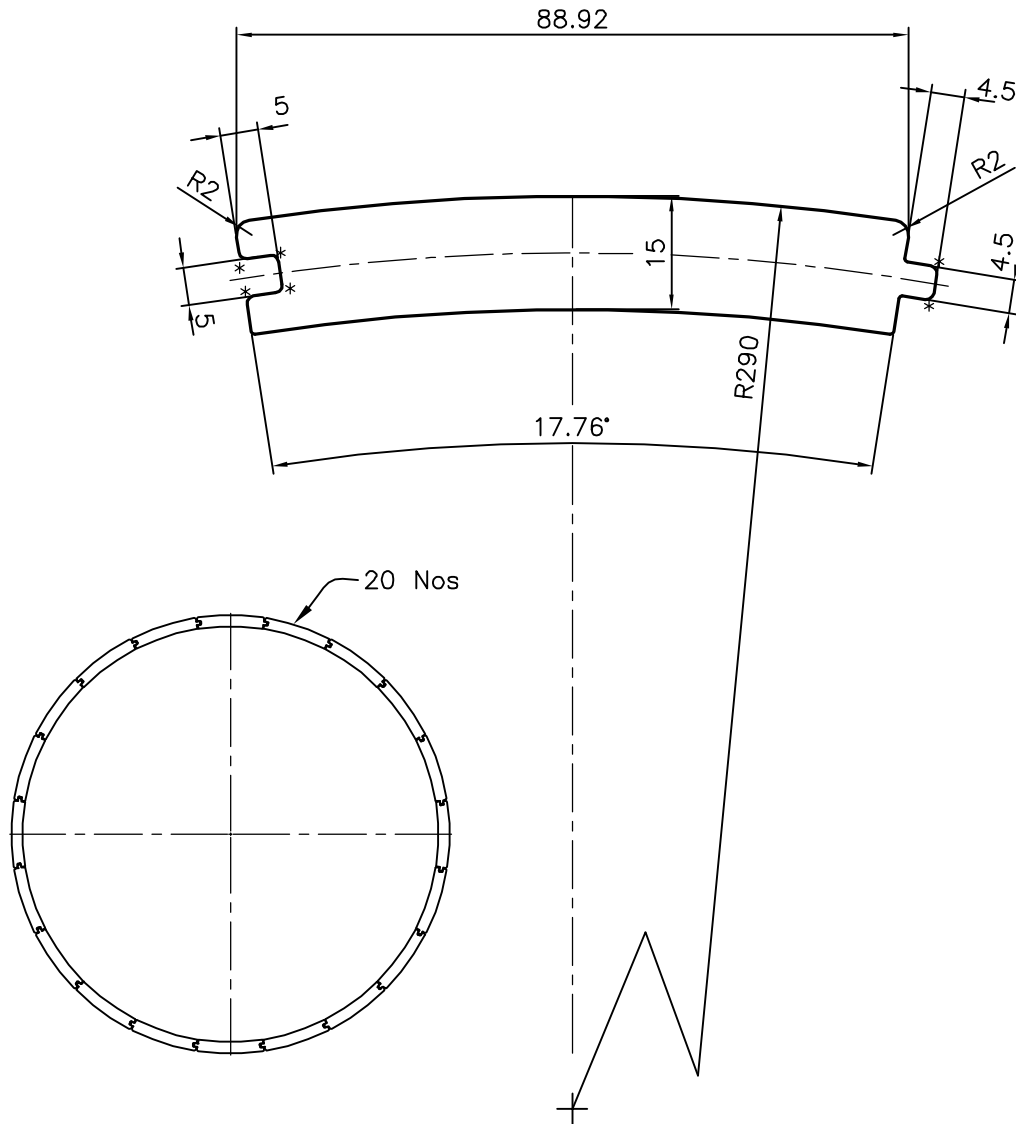

\* = 1.0 RADIUS (6 PLACES)



SYMBOL OF QUALITY  
AN ISO 9001 COMPANY

**JINDAL ALUMINIUM LTD.**  
BANGALORE-560073 (INDIA)

	NAME	DATE
DRAWN	J.P.KAUSHIK	18-06-2015
CHECKED		
APPROVED	S.S.GARG	09-07-2015

1. ALL DIMENSIONS ARE IN mm.
2. ROUND OFF ALL SHARP CORNERS WITH 0.40 mm.
3. TOLERANCES WILL BE AS PER IS:3965-1981 UNLESS OTHERWISE SPECIFIED

SCALE	1:1
AREA mm <sup>2</sup>	1305.973
PERIMETER mm.	219.06
WEIGHT kg/m	3.526

PARTY'S NAME: BAJAJ TAMBULA PINNED PRODUCTS PVT. LTD, KOLKATA

DRAWING No. SECTION No.

PARTY'S DRAWING No. BT/LR/022/15-16 AS PER AutoCAD DRAWING

P-14770-1

ALLOY & TEMPER: 6082 T6

S4520 S4520

DESCRIPTION: INTERLOCK TYPE SECTION