

P-14767

S4532

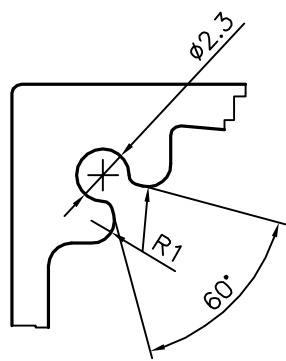

DETAIL "A"  
SCALE 3:1

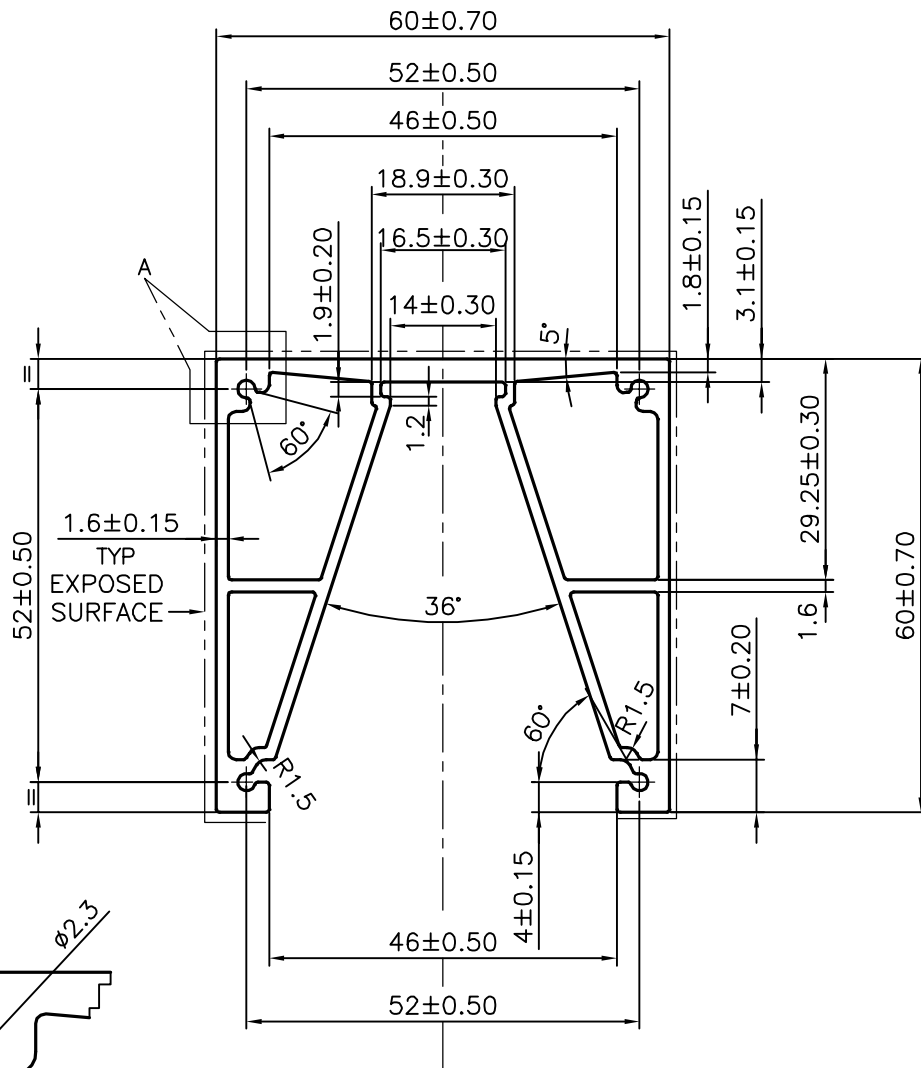

SYMBOL OF QUALITY  
AN ISO 9001 COMPANY

**JINDAL ALUMINIUM LTD.**  
BANGALORE-560073 (INDIA)

	NAME	DATE
DRAWN	J.P.KAUSHIK	12-06-2015
CHECKED		
APPROVED	S.S.GARG	13-07-2015

1. ALL DIMENSIONS ARE IN mm.
2. ROUND OFF ALL SHARP CORNERS WITH 0.40 mm.
3. TOLERANCES WILL BE AS PER IS:6477-1983 UNLESS OTHERWISE SPECIFIED

SCALE	1:1
AREA mm <sup>2</sup>	638.889
PERIMETER mm.	346.733
WEIGHT kg/m	1.725

PARTY'S NAME	PROMPTEC RENEWABLE ENERGY SOLUTIONS PVT. LTD., BANGALORE
PARTY'S DRAWING No.	AS PER AutoCAD DRAWING P00176 REV.3-A-1023
ALLOY & TEMPER	6063 T5
DESCRIPTION	FIXTURE SECTION

DRAWING No.	SECTION No.
P-14767	
S4532	S4532