

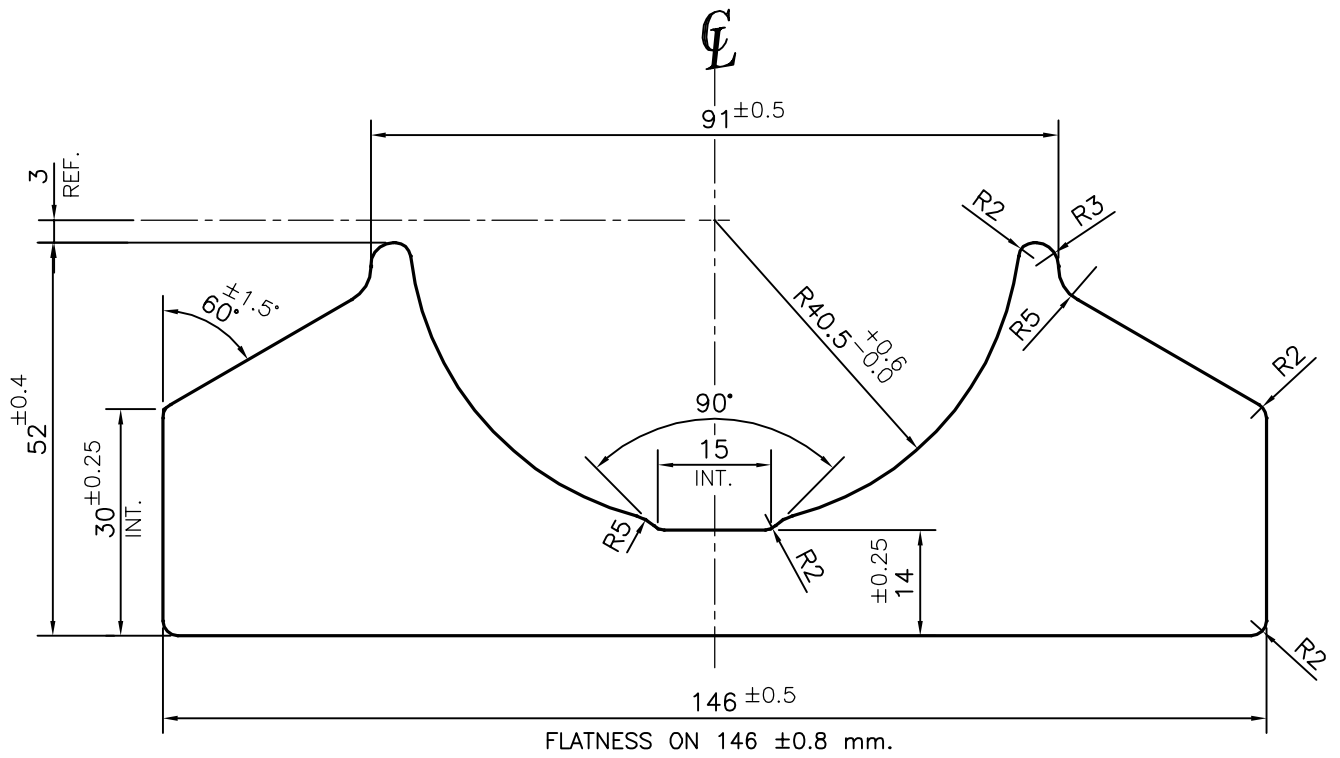

P-14687-1

S4552



 SYMBOL OF QUALITY AN ISO 9001 COMPANY	JINDAL ALUMINIUM LTD. BANGALORE-560073 (INDIA)	NAME		DATE
		DRAWN	PARVESH	16-06-2015
1. ALL DIMENSIONS ARE IN mm. 2. ROUND OFF ALL SHARP CORNERS WITH 0.40 mm. 3. TOLERANCES WILL BE AS PER BS:EN-12020-2 , UNLESS OTHERWISE SPECIFIED		CHECKED		
		APPROVED		S.S.GARG
PARTY'S NAME COFIMCO INDUSTRIAL FANS (I) PVT. LTD., CHENNAI		SCALE		1:1
		AREA mm ²		4467.276
PARTY'S DRAWING No. EXBG80		PERIMETER mm.		406.836
		WEIGHT kg/m		12.062
ALLOY & TEMPER 6060 T6		DRAWING No.		P-14687-1
		SECTION No.		-
DESCRIPTION INDUSTRIAL SECTION		S4552		S4552