

P-14859-1

S4554

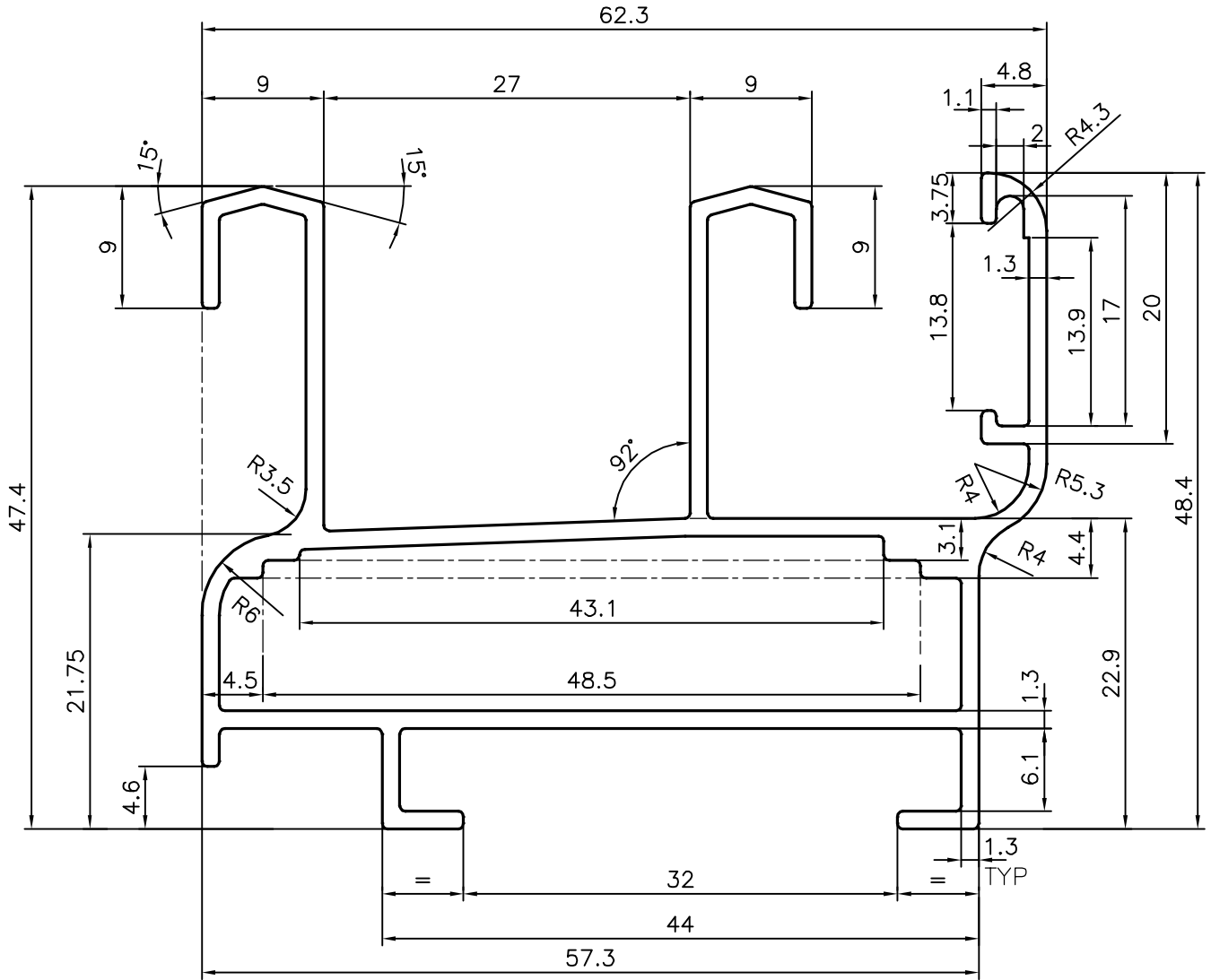
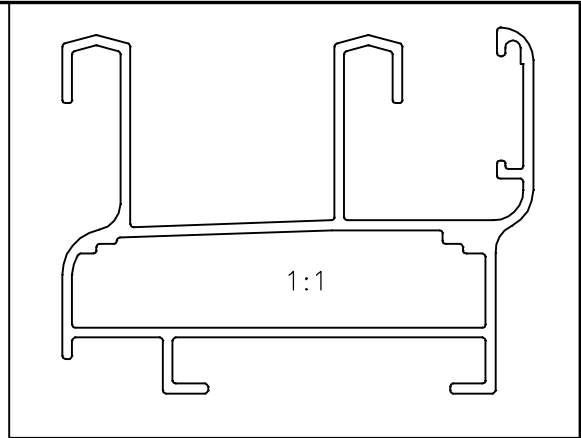

SYMBOL OF QUALITY  
AN ISO 9001 COMPANY

**JINDAL ALUMINIUM LTD.**  
BANGALORE-560073 (INDIA)

	NAME	DATE
DRAWN	J.P.KAUSHIK	16-07-2015
CHECKED		
APPROVED	S.S.GARG	30-07-2015
SCALE		2:1
AREA mm <sup>2</sup>		383.77
PERIMETER mm.		416.957
WEIGHT kg/m		1.036
DRAWING No.	SECTION No.	
P-14859-1	-	
S4554	S4554	

1. ALL DIMENSIONS ARE IN mm.
2. ROUND OFF ALL SHARP CORNERS WITH 0.40 mm.
3. TOLERANCES WILL BE AS PER IS:6477-1983, UNLESS OTHERWISE SPECIFIED

PARTY'S NAME	FULL SPACE INTERIORS, MUMBAI
PARTY'S DRAWING No.	AS PER SAMPLE
ALLOY & TEMPER	HE9 WP
DESCRIPTION	WINDOW SECTION