

P-14919

S4566

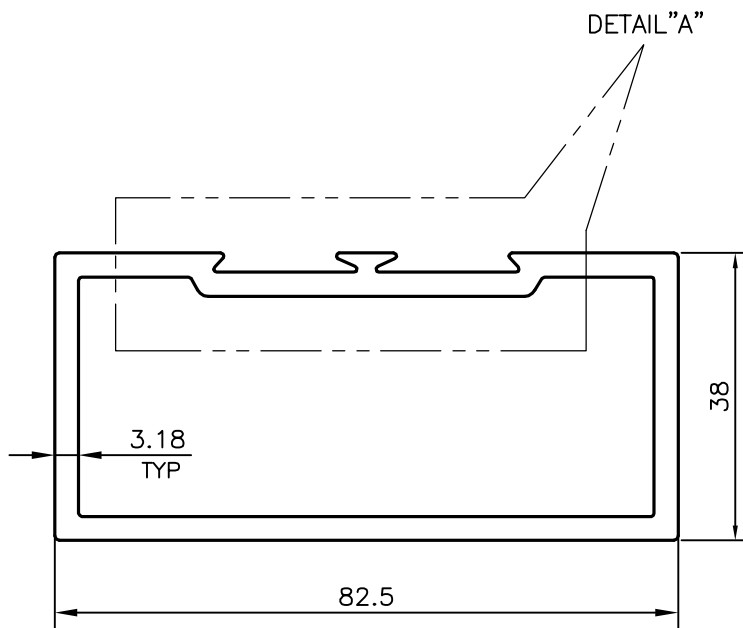

WEIGHT RANGE  $\pm 10\%$  kg/m

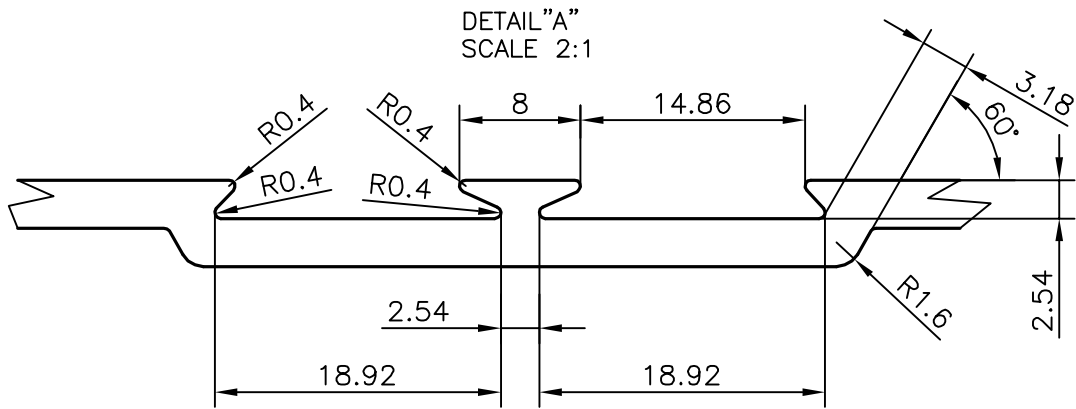

SYMBOL OF QUALITY  
AN ISO 9001 COMPANY

**JINDAL ALUMINIUM LTD.**  
BANGALORE-560073 (INDIA)

	NAME	DATE
DRAWN	J.P.KAUSHIK	24-07-2015
CHECKED		
APPROVED	S.S.GARG	12-08-2015
SCALE		1:1
AREA mm <sup>2</sup>		754.457
PERIMETER mm.		261.17
WEIGHT kg/m		2.037
DRAWING No.	SECTION No.	
P-14919	-	
S4566	S4566	

1. ALL DIMENSIONS ARE IN mm.
2. ROUND OFF ALL SHARP CORNERS WITH 0.40 mm.
3. TOLERANCES WILL BE AS PER IS:6477-1983 UNLESS OTHERWISE SPECIFIED

PARTY'S NAME	SAM INDIA BUILTWELL PVT. LTD., DELHI
PARTY'S DRAWING No.	AS PER SKETCH
ALLOY & TEMPER	HE9 WP
DESCRIPTION	PARTITION SECTION-SINGLE