

P-15041

S4595

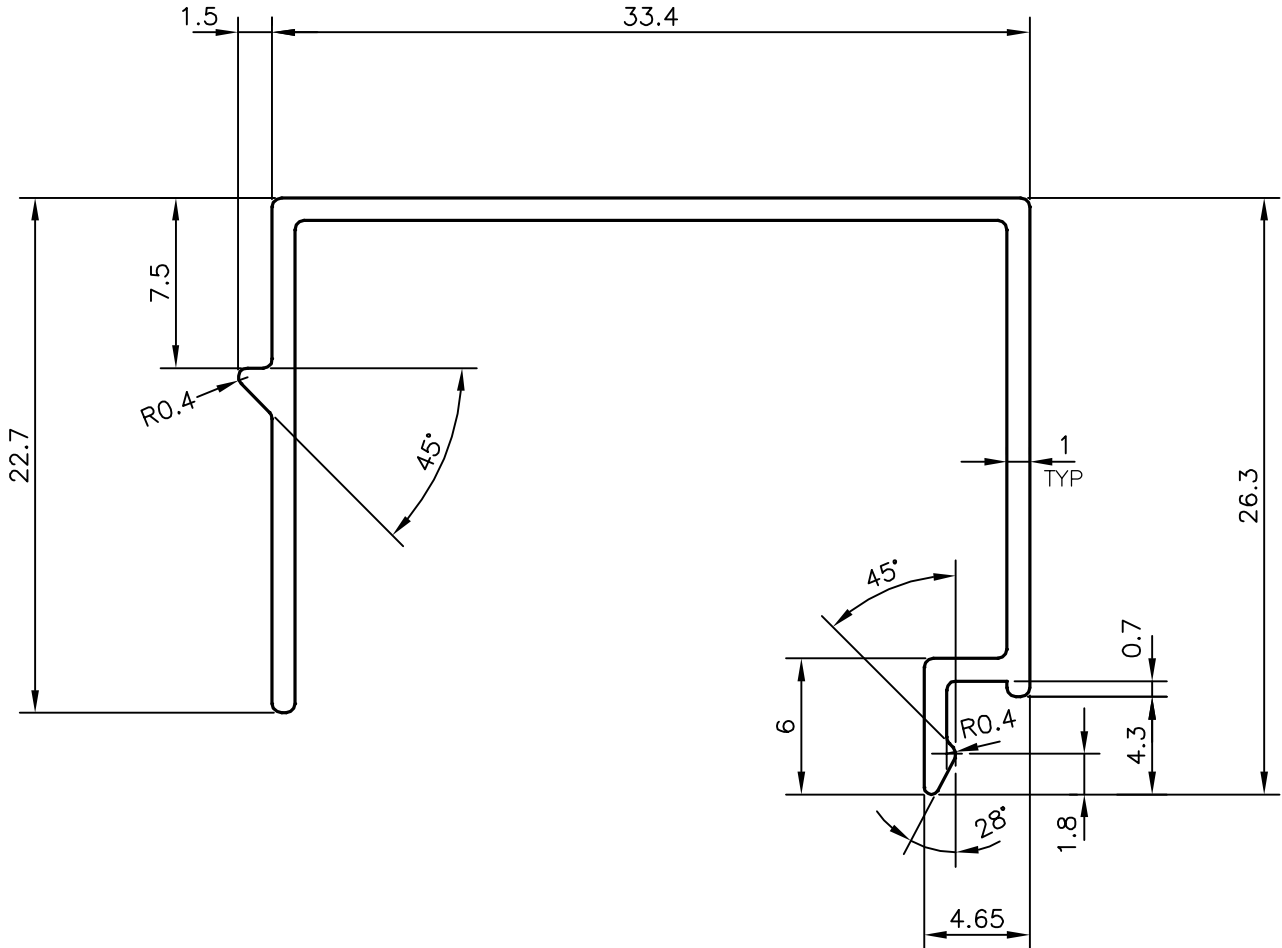
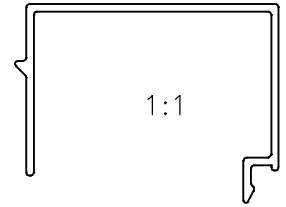

SYMBOL OF QUALITY
AN ISO 9001 COMPANY

JINDAL ALUMINIUM LTD.
BANGALORE-560073 (INDIA)

	NAME	DATE
DRAWN	J.P.KAUSHIK	14-08-2015
CHECKED		
APPROVED	S.S.GARG	21-08-2015
SCALE		3:1
AREA mm ²		86.691
PERIMETER mm.		171.034
WEIGHT kg/m		0.234
DRAWING No.	SECTION No.	
P-15041	-	
S4595	S4595	

1. ALL DIMENSIONS ARE IN mm.
2. ROUND OFF ALL SHARP CORNERS WITH 0.40 mm.
3. TOLERANCES WILL BE AS PER IS:3965-1981 , UNLESS OTHERWISE SPECIFIED

PARTY'S NAME	KARAM DASS NIRASH, MANDI
PARTY'S DRAWING No.	HW-14
ALLOY & TEMPER	6063 T6
DESCRIPTION	CLIP SECTION