

P-15052

S4615

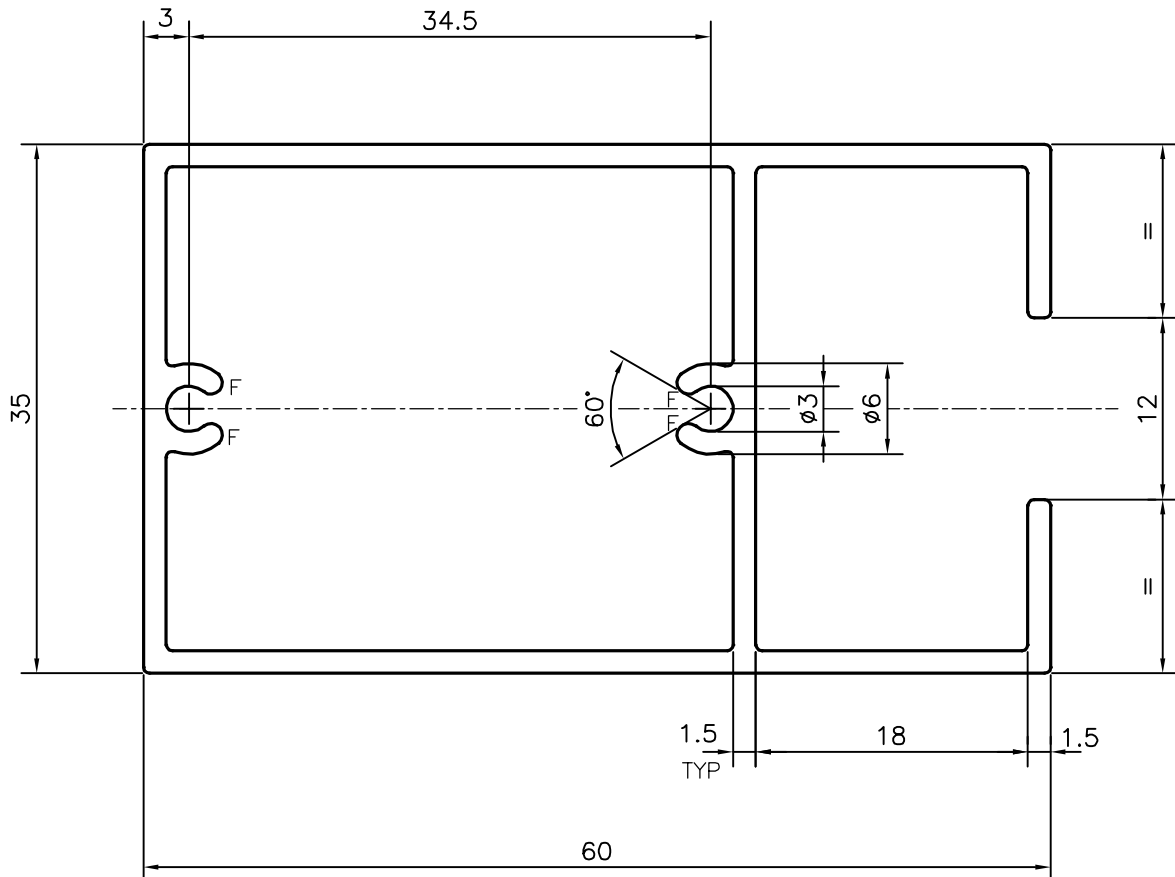

F = FULL RADIUS (4 PLACES)

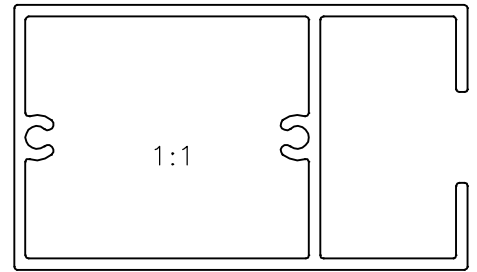

SYMBOL OF QUALITY  
AN ISO 9001 COMPANY

**JINDAL ALUMINIUM LTD.**  
BANGALORE-560073 (INDIA)

	NAME	DATE
DRAWN	J.P.KAUSHIK	17-08-2015
CHECKED		
APPROVED	S.S.GARG	26-08-2015
SCALE		2:1
AREA mm <sup>2</sup>		329.562
PERIMETER mm.		266.932
WEIGHT kg/m		0.89
DRAWING No.	SECTION No.	
P-15052	-	
S4615	S4615	

1. ALL DIMENSIONS ARE IN mm.
2. ROUND OFF ALL SHARP CORNERS WITH 0.40 mm.
3. TOLERANCES WILL BE AS PER IS:6477-1983 , UNLESS OTHERWISE SPECIFIED

PARTY'S NAME	K.S.V INFRABUILD, NEW DELHI
PARTY'S DRAWING No.	AS PER DRAWING
ALLOY & TEMPER	HE9 WP
DESCRIPTION	WINDOW SECTION