

P-15054

S4617

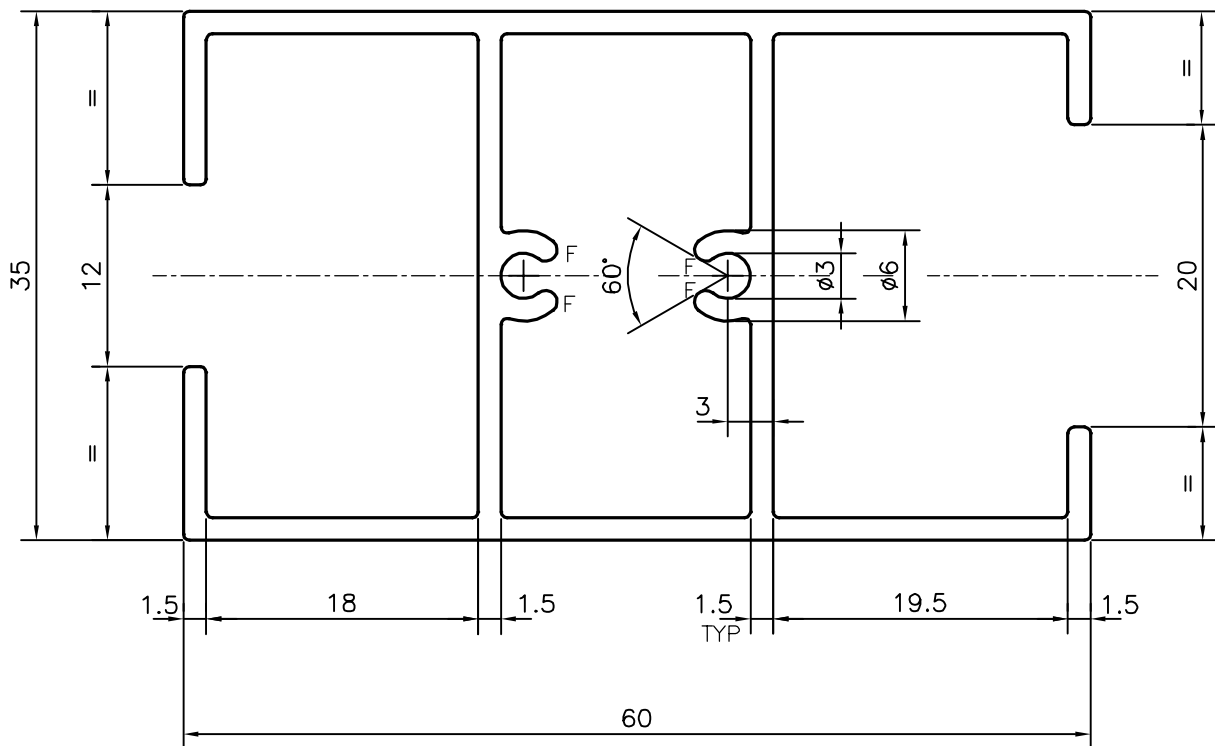

F = FULL RADIUS (4 PLACES)

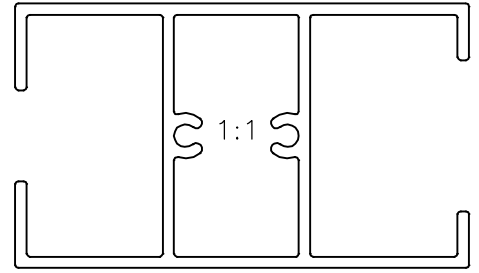

SYMBOL OF QUALITY
AN ISO 9001 COMPANY

JINDAL ALUMINIUM LTD.
BANGALORE-560073 (INDIA)

	NAME	DATE
DRAWN	J.P.KAUSHIK	17-08-2015
CHECKED		
APPROVED	S.S.GARG	26-08-2015
SCALE		2:1
AREA mm ²		347.562
PERIMETER mm.		331.558
WEIGHT kg/m		0.938
DRAWING No.	SECTION No.	
P-15054	-	
S4617	S4617	

1. ALL DIMENSIONS ARE IN mm.
2. ROUND OFF ALL SHARP CORNERS WITH 0.40 mm.
3. TOLERANCES WILL BE AS PER IS:6477-1983 , UNLESS OTHERWISE SPECIFIED

PARTY'S NAME	K.S.V INFRABUILD,NEW DELHI
PARTY'S DRAWING No.	AS PER DRAWING
ALLOY & TEMPER	HE9 WP
DESCRIPTION	WINDOW SECTION