

P-15126

S4646

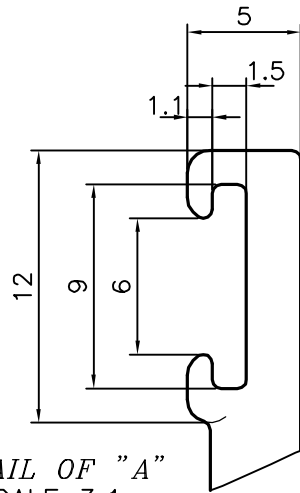

DETAIL OF "A"
SCALE 3:1

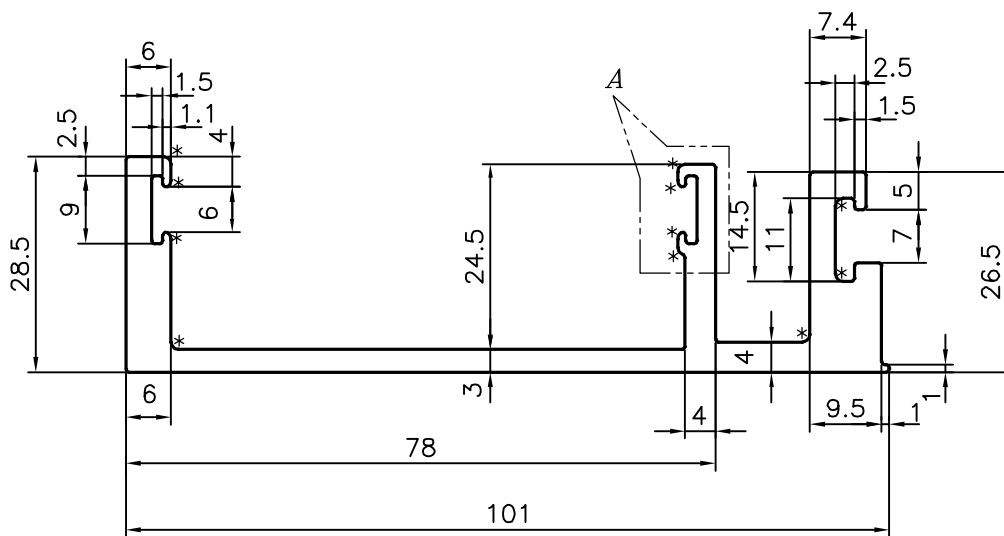
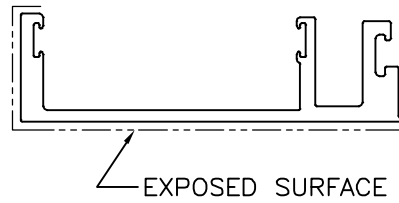

AVERAGE THICKNESS HAS TO BE MAINTAINED WITH IN ± 0.20 mm. OF THE NOMINAL VALUE.

* = 1.0 RADIUS (11 PLACES)



SYMBOL OF QUALITY
AN ISO 9001 COMPANY

JINDAL ALUMINIUM LTD.
BANGALORE-560073 (INDIA)

	NAME	DATE
DRAWN	J.P.KAUSHIK	05-09-2015
CHECKED		
APPROVED	S.S.GARG	14-09-2015
SCALE		1:1
AREA mm ²		695.892
PERIMETER mm.		384.018
WEIGHT kg/m		1.879
DRAWING No.	SECTION No.	
P-15126	-	
S4646	S4646	

1. ALL DIMENSIONS ARE IN mm. 2. ROUND OFF ALL SHARP CORNERS WITH 0.40 mm. 3. TOLERANCES WILL BE AS PER IS:3965-1981, UNLESS OTHERWISE SPECIFIED	
PARTY'S NAME	OMKAR REALTORS & DEVELOPERS PVT. LTD., MUMBAI
PARTY'S DRAWING No.	AP-1585
ALLOY & TEMPER	6063 T6
DESCRIPTION	CURTAIN WALL SECTION