

P-15163

S4678

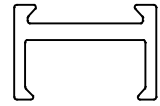

SCALE: - 1:1

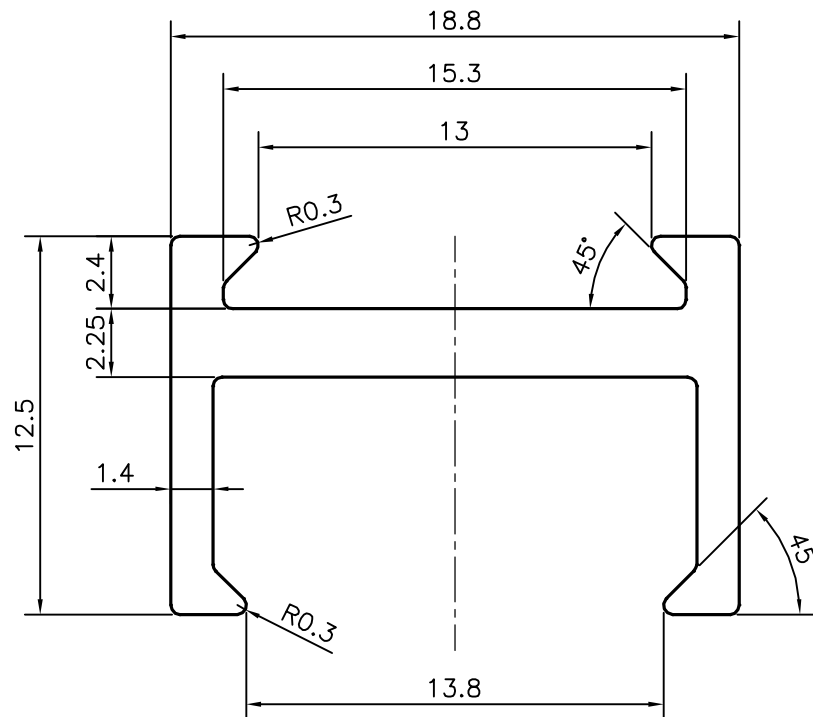

UNSPECIFIED CORNERS RADIUS WILL BE 0.30 mm.



SYMBOL OF QUALITY
AN ISO 9001 COMPANY

JINDAL ALUMINIUM LTD.
BANGALORE-560073 (INDIA)

	NAME	DATE
DRAWN	PARVESH	11-09-2015
CHECKED		
APPROVED	S.S.GARG	21-09-2015
SCALE		4:1
AREA mm ²		77.044
PERIMETER mm.		87.816
WEIGHT kg/m		0.208
DRAWING No.	SECTION No.	
P-15163	-	
S4678	S4678	

1. ALL DIMENSIONS ARE IN mm.
2. ROUND OFF ALL SHARP CORNERS WITH 0.40 mm.
3. TOLERANCES WILL BE AS PER IS:3965-1981 , UNLESS OTHERWISE SPECIFIED

PARTY'S NAME	VIGNESWARA COTTAGE INDUSTRIES, COIMBATORE
PARTY'S DRAWING No.	AS PER SAMPLE
ALLOY & TEMPER	HE9 WP
DESCRIPTION	MISC. CHANNEL