

P-15106

S4690

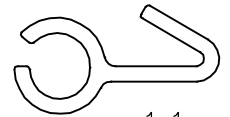

1:1

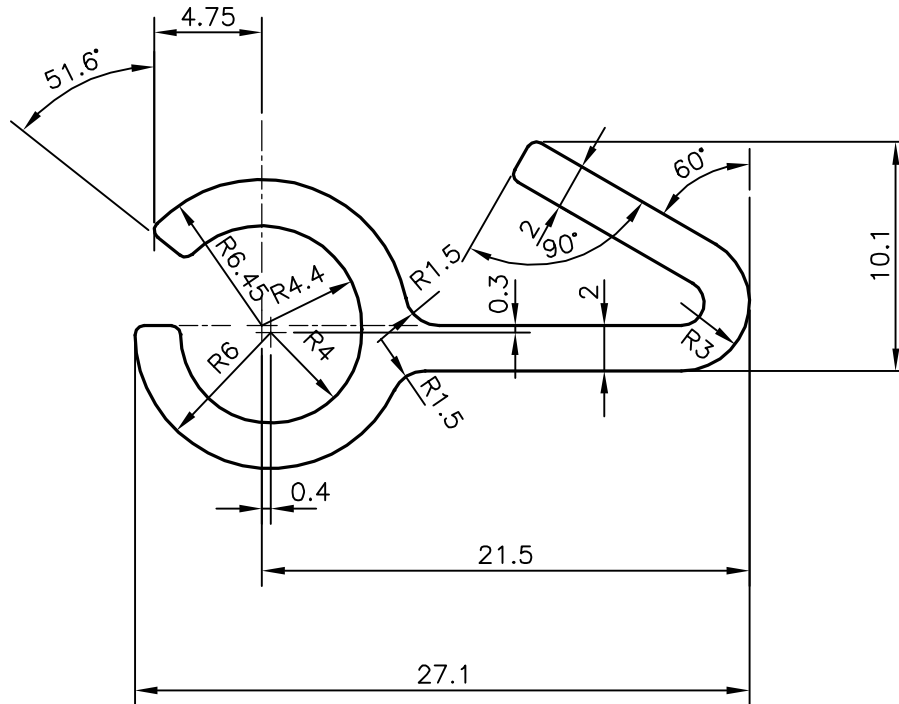

SYMBOL OF QUALITY
AN ISO 9001 COMPANY

JINDAL ALUMINIUM LTD.
BANGALORE-560073 (INDIA)

	NAME	DATE
DRAWN	J.P.KAUSHIK	31-08-2015
CHECKED		
APPROVED	S.S.GARG	25-09-2015
SCALE		3:1
AREA mm ²		113.434
PERIMETER mm.		114.742
WEIGHT kg/m		0.306
DRAWING No.	SECTION No.	
P-15106	-	
S4690	S4690	

1. ALL DIMENSIONS ARE IN mm.
2. ROUND OFF ALL SHARP CORNERS WITH 0.40 mm.
3. TOLERANCES WILL BE AS PER IS:3965-1981 , UNLESS OTHERWISE SPECIFIED

PARTY'S NAME	ELECTROSPARK, GURGAON
PARTY'S DRAWING No.	AS PER AutoCAD DRAWING
ALLOY & TEMPER	6063 T6
DESCRIPTION	MISC. SECTION