

P-15117

S4694

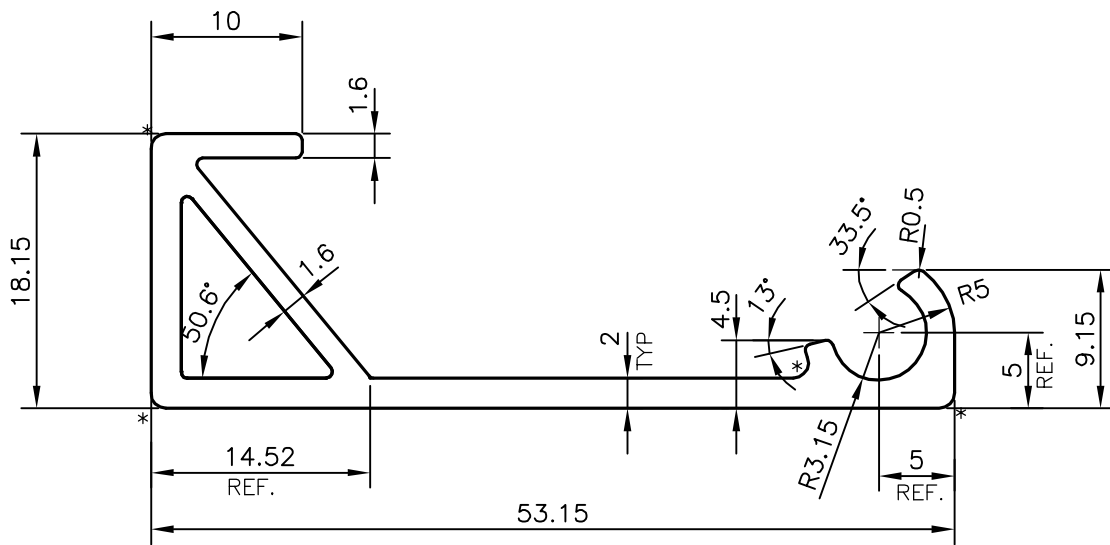

\* = 1.0 RADIUS (4 PLACES)

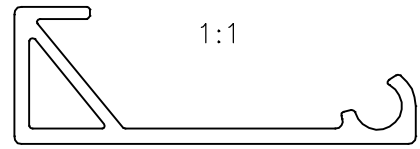
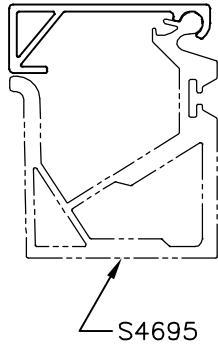

SYMBOL OF QUALITY  
AN ISO 9001 COMPANY

**JINDAL ALUMINIUM LTD.**  
BANGALORE-560073 (INDIA)

	NAME	DATE
DRAWN	J.P.KAUSHIK	02-09-2015
CHECKED		
APPROVED	S.S.GARG	25-09-2015
SCALE		2:1
AREA mm <sup>2</sup>		201.172
PERIMETER mm.		164.106
WEIGHT kg/m		0.543
DRAWING No.	SECTION No.	
P-15117	-	
S4694	S4694	

1. ALL DIMENSIONS ARE IN mm.
2. ROUND OFF ALL SHARP CORNERS WITH 0.40 mm.
3. TOLERANCES WILL BE AS PER IS:6477-1983 , UNLESS OTHERWISE SPECIFIED

PARTY'S NAME	ELECTROSPARK, GURGAON
PARTY'S DRAWING No.	AS PER AutoCAD DRAWING
ALLOY & TEMPER	6063 T6
DESCRIPTION	MISC. SECTION