

P-15183-2

S4698

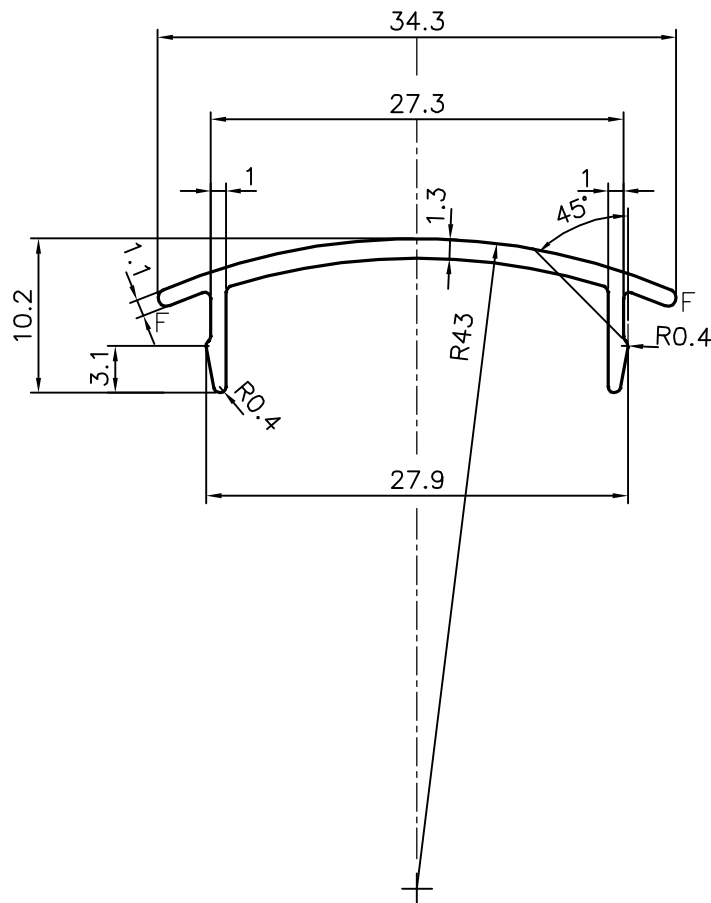

1:1

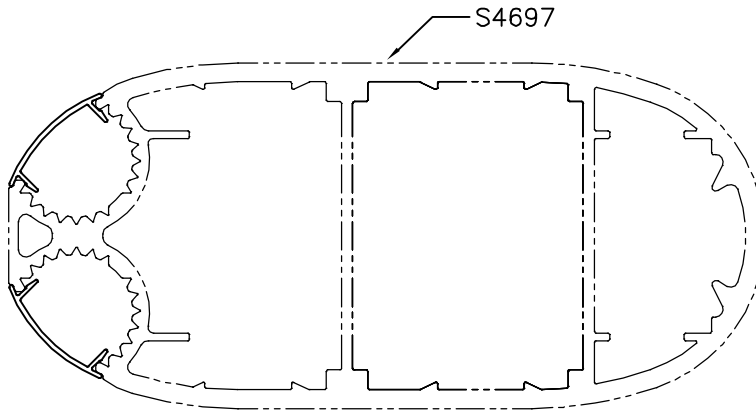

F= FULL RADIUS (2 PLACES)



SYMBOL OF QUALITY  
AN ISO 9001 COMPANY

**JINDAL ALUMINIUM LTD.**  
BANGALORE-560073 (INDIA)

	NAME	DATE
DRAWN	J.P.KAUSHIK	27-09-2015
CHECKED		
APPROVED	S.S.GARG	30-09-2015
SCALE		2:1
AREA mm <sup>2</sup>		57.954
PERIMETER mm.		97.364
WEIGHT kg/m		0.156
DRAWING No.	SECTION No.	
P-15183-2	-	
S4698	S4698	

1. ALL DIMENSIONS ARE IN mm.
2. ROUND OFF ALL SHARP CORNERS WITH 0.40 mm.
3. TOLERANCES WILL BE AS PER IS:3965-1981, UNLESS OTHERWISE SPECIFIED

PARTY'S NAME	CFFC, BANGALORE
PARTY'S DRAWING No.	AS PER AutoCAD DRAWING
ALLOY & TEMPER	6063 T6
DESCRIPTION	CLIP SECTION