

P-14961-2

S4714

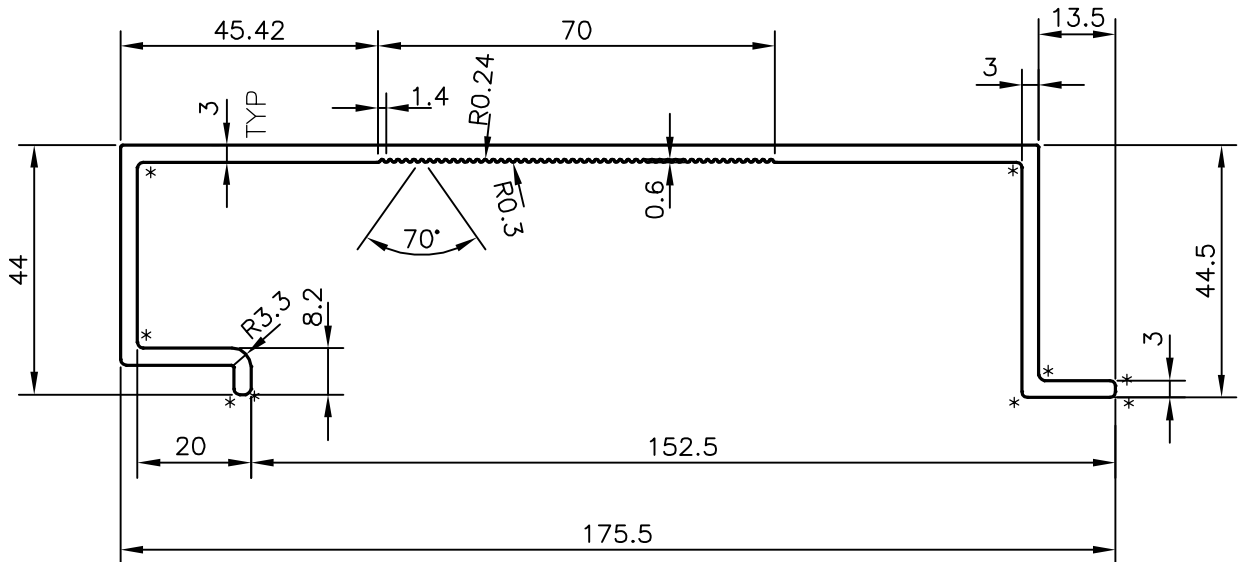

* = 1.0 RADIUS (9 PLACES)

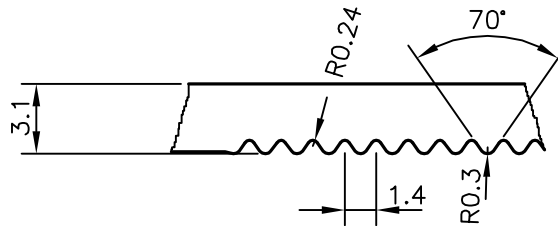
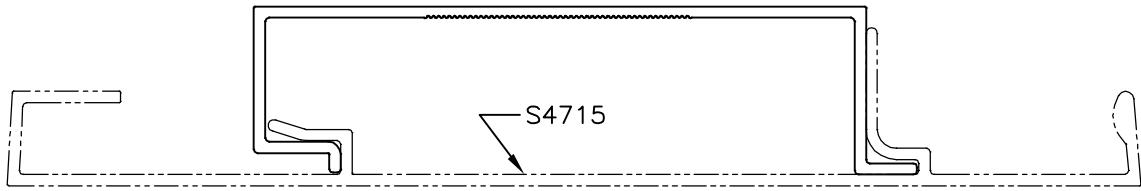

SYMBOL OF QUALITY
AN ISO 9001 COMPANY

JINDAL ALUMINIUM LTD.
BANGALORE-560073 (INDIA)

	NAME	DATE
DRAWN	J.P.KAUSHIK	29-09-2015
CHECKED		
APPROVED	S.S.GARG	26-10-2015
SCALE		0.75:1
AREA mm ²		818.071
PERIMETER mm.		582.681
WEIGHT kg/m		2.209
DRAWING No.	SECTION No.	
P-14961-2	-	
S4714	S4714	

1. ALL DIMENSIONS ARE IN mm.
2. ROUND OFF ALL SHARP CORNERS WITH 0.40 mm.
3. TOLERANCES WILL BE AS PER IS:3965-1981 , UNLESS OTHERWISE SPECIFIED

PARTY'S NAME	ALUMAYER INDIA PVT. LTD., MUMBAI
PARTY'S DRAWING No.	NCP-73
ALLOY & TEMPER	6063 T6
DESCRIPTION	MISC CHANNEL