

P-15369

S4749

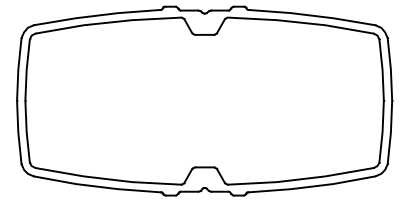

SCALE: - 1:1

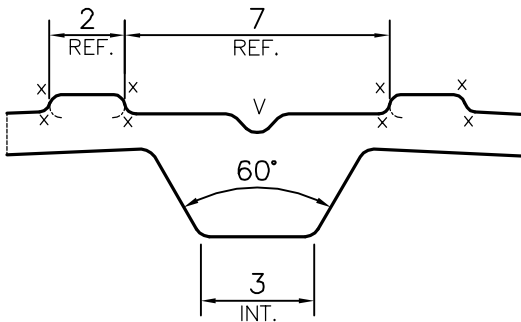
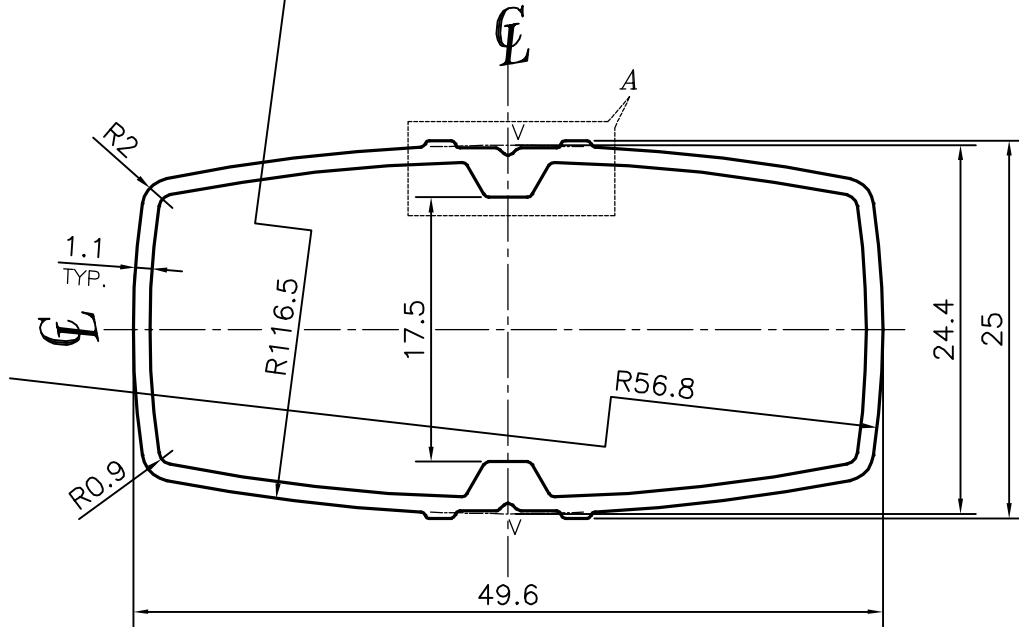

DETAIL OF "A"
SCALE 5:1

V = VEE GROOVE 0.5x90° (2 PLACES)
X = RADIUS 0.3 mm. (16 PLACES)



SYMBOL OF QUALITY
AN ISO 9001 COMPANY

JINDAL ALUMINIUM LTD.
BANGALORE-560073 (INDIA)

	NAME	DATE
DRAWN	PARVESH	27-11-2015
CHECKED		
APPROVED	S.S.GARG	05-12-2015
SCALE		2:1
AREA mm ²		163.838
PERIMETER mm.		136.689
WEIGHT kg/m		0.442
DRAWING No.	SECTION No.	
P-15369	-	
S4749	S4749	

1. ALL DIMENSIONS ARE IN mm.
2. ROUND OFF ALL SHARP CORNERS WITH 0.40 mm.
3. TOLERANCES WILL BE AS PER IS:6477-1983 , UNLESS OTHERWISE SPECIFIED

PARTY'S NAME	ADARSH ALUMINIUM WORKS, DELHI
PARTY'S DRAWING No.	LIGHTER OF SECTION No.-22049
ALLOY & TEMPER	HE9 WP
DESCRIPTION	VENETIAN BLINDS SECTION